

AXIS
OFF-ROAD

500cc/700cc

OWNER'S MANUAL



*SHOWN WITH OPTIONAL ACCESSORIES

Owner Manual

INTRODUCTION

Congratulations on your purchase of the AXIS 500/700cc. This Owner's / Operator's manual will provide you information regarding safe operation, operational instructions, maintenance and care. Fully understanding this manual and following all of the instructions herein will provide the knowledge needed to have safe and enjoyable UTV operation.

For questions regarding this UTV, please call (972) 446-0760.

IMPORTANT SAFETY MESSAGES

- **READ THIS MANUAL CAREFULLY AND COMPLETELY BEFORE OPERATING YOUR UTV. MAKE SURE YOU UNDERSTAND ALL INSTRUCTIONS.**
- **PAY CLOSE ATTENTION TO THE WARNING AND CAUTION LABELS ON THE UTV.**
- **NEVER OPERATE THE UTV WITHOUT PROPER TRAINING OR INSTRUCTION.**
- **THIS UTV SHOULD NOT BE RIDDEN BY ANYONE UNDER 16 YEARS OF AGE.**

Owner Manual

IMPORTANT MANUAL INFORMATION

FAILURE TO FOLLOW THE WARNINGS CONTAINED IN THIS MANUAL CAN RESULT IN SERIOUS INJURY OR DEATH. Particularly important information is distinguished in this manual by the following notations:



The Safety Alert Symbol means **ATTENTION!**
YOUR SAFETY IS INVOLVED!



Failure to follow **WARNING** instructions could result in severe injury or death to the machine operator, bystander or a person inspecting or repairing the machine.

CAUTION:

A CAUTION indicates special precautions that must be taken to avoid damage to the machine.

NOTE:

A NOTE provides key information to make procedures easier to understand.

Owner Manual

IMPORTANT NOTICE

This UTV is designed and manufactured for **OFF - ROAD** use only. It is illegal and unsafe to operate this UTV on any public street, road or highway.

This UTV complies with all applicable **OFF - ROAD** noise level and spark arrestor laws and regulations in effect at the time of manufacture.

Please check your local riding laws and regulations before operating this UTV.

When the temperature is below -4°F (-20°C), park the UTV in a place where the temperature is higher than -4°F (-20°C). Start the UTV after the UTV has warmed up. Please see page 6-3 on the warming up process.

Follow the proper parking procedures when the temperature is higher than 100°F (38°C): turn off the engine; make sure the radiator fan is on for 3 minutes before turning off the power switch.

Starting the UTV for the first time will take longer because the fuel will need reach the fuel injectors. To start the UTV the first time, hold the ignition key on at 5-second intervals. Allow the starter to rest 15 seconds between each start attempt.

Owner Manual

1	Location of the Warning and Specification Labels	1-1	Switches	4-9	
			Accelerator Pedal	4-14	
			Brake Pedal	4-15	
2	Safety Information	2-1	Parking Brake Lever	4-15	
			Drive Select Lever	4-16	
			Fuel Tank Cap	4-17	
3	Description and Vehicle Identification	3-1	Seats	4-17	
	Identification Number Records	3-3	Seat Belts	4-18	
	Vehicle Identification Number	3-3	Glove Compartment	4-21	
			Cargo Bed	4-21	
4	Control Functions	4-1	Opening and Closing the Tailgate	4-22	
	Main Switch	4-1	Lifting and Lowering the Cargo Bed	4-22	
	Indicator and Warning Lights	4-2	Front and Rear Shock Absorber		
	Use of EPS system	4-4	Adjustment	4-24	
	Speedometer Unit	4-6	Trailer Hitch Bracket	4-30	
	Odometer and Trip Meter Modes	4-6	Auxiliary DC Jack	4-31	
	Clock time adjustment	4-7			
	Fault code indicator	4-8			
	Fuel level indicator	4-9			
			5	Pre Operation Checks	5-1
				Brakes	5-2

Owner Manual

Brake Fluid Level	5-2	How to Measure Tire Pressure	5-12
Brake Fluid Leakage	5-3	Tire Wear Limit	5-13
Brake Operation	5-3		
Fuel	5-4	6 Operation	6-1
Gasohol	5-4	Starting the Engine in Low	
Engine Oil	5-5	Temperatures	6-1
Coolant	5-6	Starting the Engine	6-2
Final Gear Oil	5-7	Warming Up	6-3
Differential Gear Oil	5-7	Drive Select Lever Operation and	
Throttle Pedal	5-8	Driving In Reverse	6-4
Throttle Freeplay	5-9	Parking	6-8
Throttle Freeplay Inspection	5-9	Parking on a Slope	6-8
Throttle Freeplay Adjustment	5-9	Vehicle Break-in Period	6-9
Steering Wheel Inspection	5-10	Engine Break-In	6-10
Seat Belts	5-10	Accessories	6-11
Fittings and Fasteners	5-10	Loading	6-12
Lights	5-10		
Switches	5-11	7 Driving Your Vehicle	7-1
Tires	5-11	Getting to Know Your Vehicle	7-1

Owner Manual

Learning to Operate Your Vehicle	7-5	To Change the Engine Oil	8-12
Turning your Vehicle	7-6	Final Gear Oil	8-15
Braking	7-8	Changing the Final Gear Oil	8-17
Going Uphill	7-8	Differential Gear Oil	8-18
Going Downhill	7-10	Changing The Differential Gear Oil	8-19
Crossing Through Shallow Water	7-12	Coolant	8-20
Riding Over Rough Terrain	7-15	Axle Boots	8-21
Riding in Brush or Wooded Areas	7-17	Spark Plug Inspection	8-22
Encountering Obstacles on the Trail	7-17	Inspection	8-23
		Installation	8-23
		Cleaning the Air Filter Elements	8-24
		Check Fuel Line and Fuel Filter	8-28
		Cleaning the Spark Arrester	8-30
		Valve Clearance	8-31
		Front Brake Pad Check	8-31
		Rear Brake Pad Check	8-32
		Checking the Brake Fluid Level	8-33
		Brake Fluid Replacement	8-34
		Checking the Brake Pedal	8-34
8	Periodic Maintenance and Adjustment		
	Service Intervals	8-3	
	Lubrication Recommendations	8-7	
	Hood	8-9	
	Console	8-10	
	Engine Oil and Oil Filter Cartridge	8-11	
	To Check the Engine Oil Level	8-11	

Owner Manual

Parking Brake Lever Free Play Adjustment	8-35	Troubleshooting Solution to Common Problems in the Vehicle	8-51 8-52
Brake Light Switch Adjustment	8-37		
Cable Inspection and Lubrication	8-37		
Brake Pedal and Accelerator Pedal Lubrication	8-38	9 Cleaning and Storage	9-1
Rear Knuckle Upper and Lower Pivot Lubrication	8-39	Cleaning	9-1
Steering Shaft Lubrication	8-39	Storage	9-3
Wheel Removal	8-40	10 Specifications	10-1
Wheel Installation	8-40		
Battery	8-41	11 Fault code of Electronic Injection System	11-1
Battery Maintenance	8-43		
Fuse Replacement	8-43	12 USA EPA Emissions Limited Warranty	12-1
Replacing Headlight Bulb	8-45		
Headlight Beam Adjustment	8-48		
Tail/brake Light Bulb Replacement	8-49		

1-1 Warning and Safety Labels

Read and understand all of the labels on your vehicle. They contain important information for safe and proper operation of your vehicle.

Never remove any labels from your vehicle. If a label becomes difficult to read or comes off, a replacement label is available by contacting your dealer.

1.



2.



3.



4.

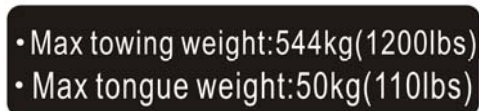

5.



7.



6.



8.



1-3 Warning and Safety Labels

9.



11.

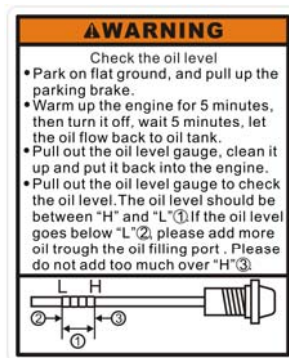

10.



12.

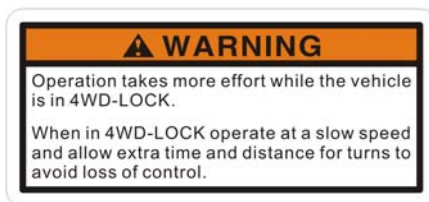

13.

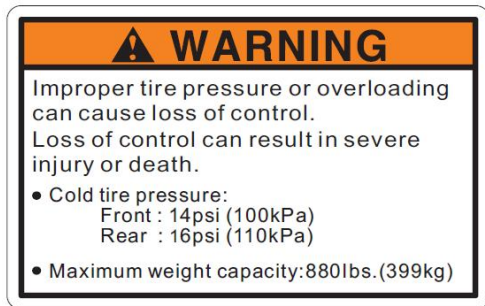

15.



14.

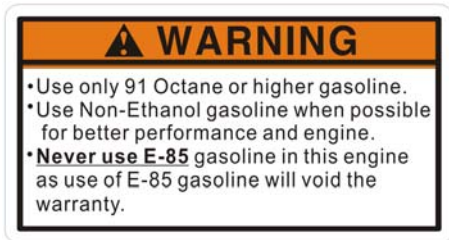

16.



1-5 Warning and Safety Labels

17.

⚠ WARNING

Improper Use of Off-Highway Vehicles Can Cause Severe Injury or Death

Be Prepared

- Fasten seat belts.
- Wear an approved helmet and protective gear.
- Each rider must be able to sit with back against seat, feet flat on floor (and foot rests), and hands on steering wheel or handhold(s), where equipped. Stay completely inside the vehicle.

Drive Responsibly

Avoid loss of control and rollovers:

- Avoid abrupt maneuvers, sideways sliding, skidding, or fishtailing, and never do donuts.
- Slow down before entering a turn.
- Avoid hard acceleration when turning, even from a stop.
- Plan for hills, rough terrain, ruts, and other changes in traction and terrain. Avoid paved surfaces.
- Avoid side hilling (riding across slopes).



Rollovers have caused severe injuries and death, even on flat, open areas.

Be Sure Riders Pay Attention and Plan Ahead

If you think or feel the vehicle may tip or roll, reduce your risk to injury:

- Keep a firm grip on the steering wheel or handholds and brace yourself.
- Do not put any part of your body outside of the vehicle for any reason.

Require Proper Use of Your Vehicle

Do your part to prevent injuries:

- Do not allow careless or reckless driving.
- Make sure operators are 16 or older with a valid driver's license.
- Do not let people drive or ride after using alcohol or drugs.
- Do not allow operation on public roads (unless designated for off-highway vehicle access)—collisions with cars and trucks can occur.
- Do not exceed seating capacity: 1 passenger.



[Locate and] Read [Owner's Manual]
Follow All Instruction and Warnings
[Reserved for Reference to Other Sources of Safety Information]



This off-highway utility vehicle handles differently from other vehicles including cars and UTVs.

SEVERE INJURY OR DEATH can result if you do not follow these instructions:

- Read this manual and all labels carefully and follow the operating procedures described.
- This vehicle is designed to carry the driver and one passenger. **NEVER CARRY PASSENGERS IN THE CARGO BED.**
- Always be sure the driver and passenger are wearing seat belts.
- Never give a ride to a passenger who is too small to reach and hold the handgrip fixed before the seat.
- Always avoid operating the vehicle on any paved surfaces, including sidewalks, driveways, parking lots, and streets.
- Never operate this vehicle on any public street, road, or highway, even dirt or gravel streets.
- Never operate this vehicle without wearing an approved motorcycle helmet that fits properly. You should also wear eye protection (goggles or a face shield), gloves, over-the-ankle boots, long-sleeved shirt or jacket, and long pants.
- Never consume alcohol or drugs before or while operating this vehicle.
- Never operate at speeds too fast for your skills or the conditions. Always go at a speed that is proper for the terrain, visibility, operating conditions, and your experience.

2-2 Safety Information

- Never attempt jumps or other stunts.
- Always inspect your vehicle each time you use it to be sure it is in safe operating condition, Always follow the inspection and maintenance procedures and schedules described in this manual.
- Always keep hands, arms, feet, and legs inside the vehicle at all times during operation. Keep your feet on the floorboard. Never hold onto the enclosure. Your hand could be injured if it is caught between the enclosure and an obstacle outside the vehicle.
- Always keep both hands on the steering wheel when driving.
- Never wrap your thumbs and fingers around the steering wheel. This is particularly important when driving in rough terrain. The front wheels will move right and left as they respond to the terrain, and this movement will be felt in the steering wheel. A sudden jolt could wrench the steering wheel around, and your thumbs or fingers could be injured if they are in the way of the steering wheel spokes.
- Always go slowly and be extra careful when operating on unfamiliar terrain. Always be alert to changing terrain conditions when driving the vehicle.
- Never operate on excessively rough, slippery, or loose terrain until you have learned and practiced the skills necessary to control the vehicle on such terrain. Always be especially cautious on these kinds of terrain.
- Never turn at excessive speed. Practice turning at slow speeds before attempting to turn at faster speeds. Do not attempt turns on steep inclines.
- Never operate the vehicle on hills that are too steep for it or for your abilities. Go straight up and down hills where possible. Maximum slope angle: 15°.

- Never operate on hills that are slippery or ones where you will not be able to see far enough ahead of you. Never go over the top of a hill at speed if you cannot see what is on other side.
- Always follow proper procedures for going uphill. If you lose control and cannot continue up a hill, back down the hill with the engine in reverse gear. Use engine braking to help you go slowly. If necessary, use the brakes gradually to help you go slowly.
- Always check terrain before going down hills. Go as slowly as possible. Never go down a hill at high speed.
- Always check for obstacles before operating in a new area.
- Never operate the vehicle in fast flowing water or water deeper than the floorboards on this model. Remember that wet brakes may have reduced stopping ability. Test your brakes after leaving water. If necessary, apply the brake several times to let friction dry out the linings.
- Always be sure there are no obstacles or people behind you when you operate in reverse. When it is safe to proceed in reverse, go slowly.
- Do not brake abruptly when carrying loads in the cargo bed.
- Always use the size and type of tires specified in this manual.
- Always make sure the tires have the proper tire pressure as described in this manual.
- Never exceed the stated load capacity. Cargo should be as far forward in the bed as possible, and distributed evenly from side to side. Be sure cargo is secured so that it cannot move around during operation. Reduce speed and follow instructions in this manual for carrying cargo or pulling a trailer. Allow greater distance for braking.

WARNING

POTENTIAL HAZARD

Improper handling of gasoline.

WHAT CAN HAPPEN

Gasoline can catch fire and you could be burned.

HOW TO AVOID THE HAZARD

Always turn off the engine when refueling. Do not refuel right after the engine has been running and is still very hot. Do not spill gasoline on the engine or exhaust pipe (or muffler) when refueling. Never refuel while smoking, or while in the vicinity of sparks, open flames, or other sources of ignition such as the pilot light of water heaters and clothes dryers. When transporting the vehicle in another vehicle, be sure it is kept in an upright position. Otherwise, fuel may leak out of the engine or fuel tank.

WHAT CAN HAPPEN

Gasoline is poisonous and can cause injuries.

HOW TO AVOID THE HAZARD

If you should swallow some gasoline or inhale a lot of gasoline vapor, or get some gasoline in your eyes, see your doctor immediately. If gasoline spills on your skin, wash with soap and water. If gasoline spills on your clothing, change your clothes.

 **WARNING**

POTENTIAL HAZARD

Starting or running the engine in a closed area.

WHAT CAN HAPPEN

Exhaust fumes are poisonous and may cause loss of consciousness and death within a short time.

HOW TO AVOID THE HAZARD

Always operate your vehicle in an area with adequate ventilation.

3-1 Description and Vehicle Identification

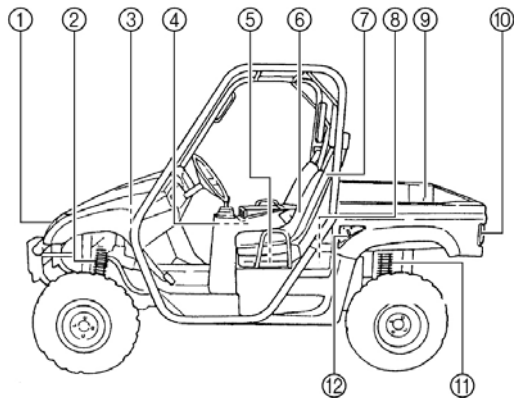

1. Headlights
2. Front shock absorber assembly adjusting ring
3. Brake fluid reservoir
4. Air filter element(engine and air intake duct)
5. V-belt case
6. Driver seat
7. Driver seat belt
8. Spark plug
9. Cargo bed
10. Tail/brake lights
11. Rear shock absorber assembly adjusting ring
12. Cargo bed release levers

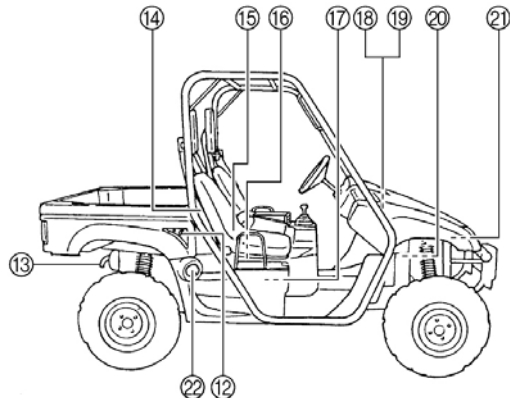

13. Spark arrester
14. Passenger seat belt
15. Passenger seat
16. Oil filter cartridge
17. Engine oil dipstick
18. Battery
19. Fuses
20. Coolant reservoir
21. Radiator cap
22. Fuel tank cap

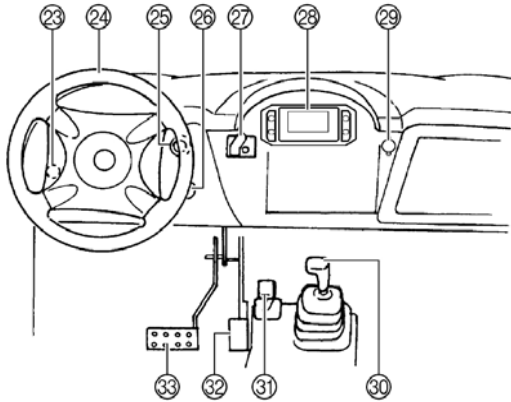

- 23. Light switch
- 24. Steering wheel
- 25. Starter
- 26. Main switch
- 27. On-Command four-wheel-drive and differential lock switches
- 28. Multi-function meter unit
- 29. Auxiliary DC jack
- 30. Drive select lever
- 31. Parking brake lever
- 32. Accelerator pedal
- 33. Brake pedal

NOTE:

The vehicle you have purchased may differ slightly from those in the figures of this manual.

3-3 Description and Vehicle Identification

Identification Number Records

Record the Vehicle Identification Number and model label information in spaces provided for assistance when ordering spare parts from a service center or for reference in case the vehicle is stolen.

1. VEHICLE IDENTIFICATION NUMBER:

2. MODEL LABEL INFORMATION

Vehicle Identification Number

The Vehicle Identification Number (VIN) is stamped into the frame.

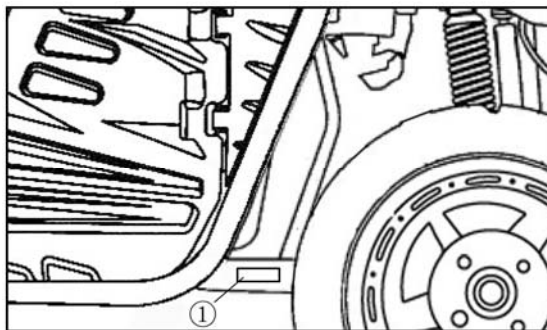

1. Vehicle identification number

NOTE:

The vehicle identification number (VIN) is used to identify your vehicle.

CONTROL FUNCTIONS

Main switch

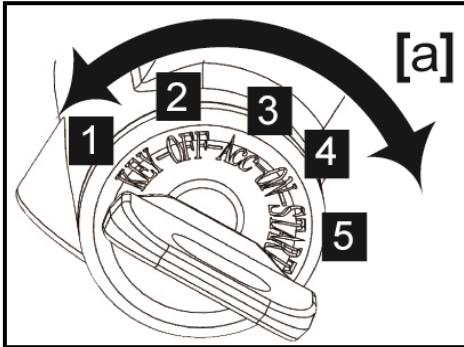

1. Main switch

Functions of the respective switch positions are as follows:

ON:

All electrical circuits are supplied with power, and the headlights and taillights illuminate when the light switch is on.

OFF:

All electrical circuits are switched off. The key can be removed in this position.

START:

The electric starter is engaged by turning and holding the key in this position. Release the key when the engine starts.

4-2 Control Functions

CAUTION:

- Do not operate the electric starter continuously for more than 5 seconds at a time or starter damage could occur. Wait at least 5 seconds between each start attempt.
- Do not turn the key to the “START” position with the engine running, or damage to the electric starter can result.
- See starting instructions prior to starting the engine. (See pages 6-1 - 6-3 for details.)

Indicator and Warning Lights

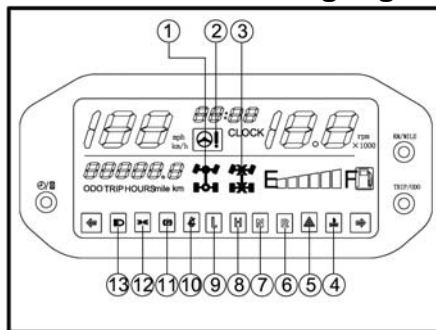

1. Four-wheel locked showing light
2. Fault indicator light of EPS system
3. differential gear lock indicator
4. Coolant temperature warning light
5. Emergency indicator
6. Reverse indicator light "R"
7. Neutral indicator light "N"
8. High-range indicator light "H"
9. Low-range indicator light "L"
10. Seat belt Indicator
11. Mechanical parking brake indicator light "P"
12. Position indicator
13. Far light indicator

Low-Range Indicator Light “L”

This indicator light comes on when the drive select lever is in the “L” position.

Mechanical Parking Brake Indicator Light “”

This indicator light comes on when the mechanical parking brake is applied.

High-Range Indicator Light “H”

This indicator light comes on when the drive select lever is in the “H” position.

Neutral Indicator Light “N”

This indicator light comes on when the drive select lever is in the “N” position.

Reverse Indicator Light “R”

This indicator light comes on when the drive select lever is in the “R” reverse position.

Coolant Temperature Warning Light “”

When the coolant temperature reaches a specified level, this light comes on to warn that the coolant temperature is too hot. If the light comes on during operation, stop the engine as soon as it is safe to do so and allow the engine to cool down for about 15 minutes.

CAUTION: _____

- The engine may overheat if the vehicle is overloaded. If this happens, reduce the load to specification.

4-4 Control Functions

- After restarting, make sure that the light is out. Continuous use while the light is on may cause damage to the engine.

High beam indicator

The light being on means headlight is at high beam mode.

Position light indicator

The light being on means that the position light fixed in the front headlight has been turned on.

Emergency indicator “ The light being on means emergency lamp is on.

Use of EPS system

Meter is an important part of UTV.

Meter works together with EPS system and monitors working condition of EPS system.

Fault can be displayed by fault indicator light and fault indicator of EPS system, so the driver can acknowledge fault of EPS in time and take some measures to keep himself/herself safe.

When fault occurs on EPS system, fault indicator light will be lit up. At the same time, fault indicator of EPS system will display the fault code for maintenance.

- Open main switch of UTV, and EPS system will automatically enter into working state.

- Check the meter. If fault indicator light of EPS system does not be lit, ECU can be for regular use.
- If fault indicator light of EPS system is lit, that means EPS system find out some fault during ECU self-checking process, then you should consult your local dealer for maintenance in time.

Speedometer Unit

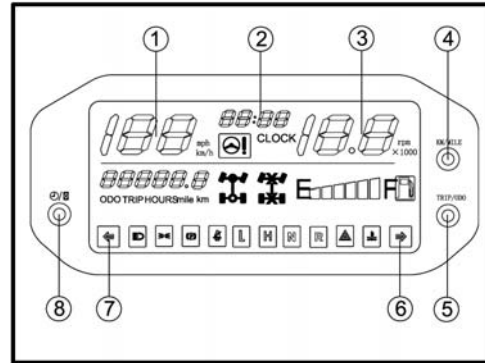

1. Speed indicator
2. Clock/Hour/ fault code meter
3. RPM indicator
4. Metric/mile button
5. "TRIP/ODO" button
6. Right turn indicator light
7. Left turn indicator light
8. Clock/Hour/ fault code reset button 

4-6 Control Functions

Speedometer unit functions:

- a speedometer (which shows the speed)
- an odometer (which shows the total distance covered)
- a tripometer (which can be cleared and then show any new distances traveled)
- an RPM indicator (which shows the revolutions per minute of the engine)
- a clock
- an EFI fault code indicator (which shows the fault code for problems with the EFI)

Odometer and trip meter modes

On the display panel there are two large buttons, one located on the left side and one on the right side. Quickly pressing the button on the left side toggles the display

from the odometer, to the tripometer, and then to the hours meter; then it starts the cycle over.

The odometer displays the total distance traveled by the UTV. The tripometer records distances for a specific trip and can record distances from 0 through 999.9 miles. To reset a trip meter, select it by pressing the left button, Press left button to switch to small mileage (Trip), press the right button for a long time to reset. The tripometer can be used to estimate the distance that can be traveled with a full tank of fuel. This information will enable you to judge the fuel consumption.

To change the display from miles per hour to kilometers per hour press the right side

button on the display. This will also change the displayed mileage from miles to kilometers.

Clock time adjustment

Press the left button and hold for three seconds and the clock goes into the hour 'set' mode.

1. Press the right button to set the hour.
2. Press the left button again and the clock goes into the minute 'set' mode.
3. Press the right button to set the minutes.
4. Press the left button again and the clock will exit the 'set' mode.

Four-wheel drive indicator

There are two 4WD indicators on the display panel. The left 4WD indicator has a blinking

circle on the front axle when the grey and yellow 4WD selector buttons are pressed in indicating the "4WD" function has been activated. This position also indicates that the 4WD is NOT locked. This allows the wheels on the left and right sides to rotate at different speeds to accommodate turning.

Differential gear lock indicator

The right 4WD symbol will show an 'X' over the center of the front axle when the lever is moved to the right and the yellow differential gear lock button is set to out position, which means the differential is not operational and is locked. When riding an UTV on muddy and slippery roads or when climbing a steep hill, make sure the 4WD lock indicator is on.

4-8 Control Functions

When riding on a flat road at a comparatively high speed, adjust the settings to “2WD/UNLOCK” and there are no symbols in either of the 4WD indicators.

Riding an UTV while the differential is functioning and is NOT locked, may improve the stability and safety of the UTV operation.

CAUTION: _____

When the selector is set to 4WD, the right 4WD symbol front axle will have an ‘X’ in the middle . When riding on good surfaces you should unlock the differential and press in the yellow and the gray buttons to the 2WD unlocked position. There should be no symbols showing in either the left or right 4WD indicators.

CAUTION: _____

If the display indicators flash or the speedometer does not show the speed while the UTV is in motion, Ask a dealer to check the speed sensor and circuits.

Fault code indicator

When the EFI encounters faults, the ECU will send the fault code to the instrument display, and it will flash on the clock.

If there are more than one fault code, they will be shown in rolling sequence. When fault codes are present, in order to see the time press the clock button, the time will be shown. Then after five seconds, the fault code returns again. Only after the fault is

fixed, will the time show automatically.

The description for the fault codes are shown in Chapter 11 of this manual.

Fuel level indicator

The fuel level display will indicate the fuel volume. When the fuel is getting low the fuel pump symbol will flash.

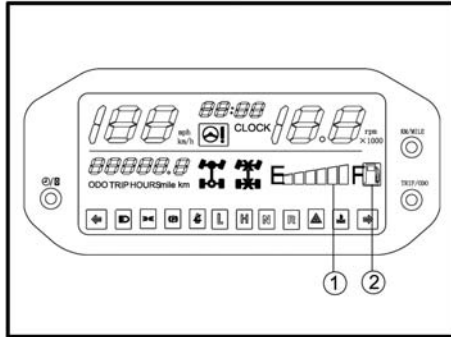

1. Fuel level indicator 2. Fuel level warning indicator

Switches

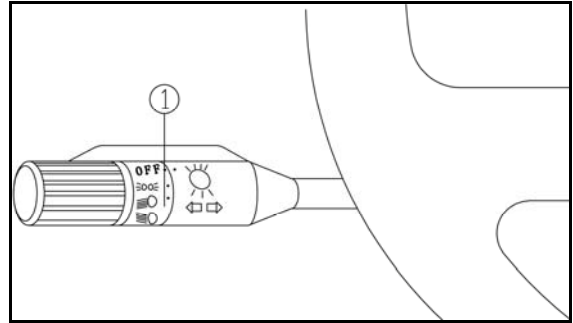

1. Light switch “OFF/☀️/☀️”

Light switch “OFF/☀️/☀️”

Set the switch to “☀️” to turn on the low beam and the taillights.

Set the switch to “☀️” to turn on the high beam and the taillights.

Set the switch to “OFF” to turn off all the lights.

4-10 Control Functions

CAUTION:

Do not use the headlights with the engine turned off for an extended period of time. The battery may discharge to the point that the starter motor will not operate properly. If this happens, remove the battery and recharge it.

On-Command Four-Wheel-Drive and Differential Gear Lock Switches

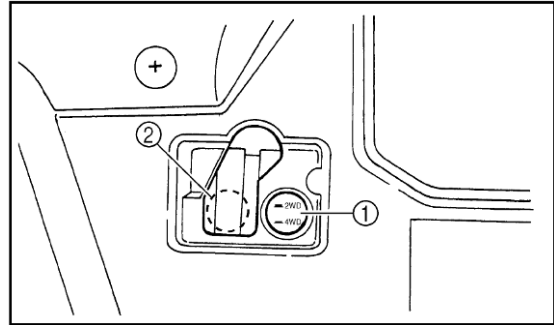

1. On-Command four-wheel –drive switch “2WD”/ “4 WD”
2. Differential gear lock switch “LOCK”/ “4WD”

This vehicle is equipped with an On-Command four-wheel-drive switch “2WD”/ “4WD” and a differential gear lock switch “4WD”/ “LOCK”. Select the appropriate drive according to terrain and the

conditions.

- Two-wheel drive ("2WD"): Power is supplied to the rear wheels only.
- Four-wheel drive ("4WD"): Power is supplied to the rear and front wheels.
- Four-wheel drive with the differential gear locked ("4WD-LOCK"): Power is supplied to the rear and front wheels when the differential gear is locked. Unlike the 4WD mode, all wheels turn at the same speed regardless of traction.

WARNING

POTENTIAL HAZARD

Changing from 2WD to 4WD or from 2WD to 2WD-Differential UNLOCK, or vice-versa while the vehicle is moving.

WHAT CAN HAPPEN

The vehicle handles differently in 4WD than in 2WD and in 2WD- Differential UNLOCK in some circumstances. Changing from 2WD to 4WD or from 2WD to 2WD-Differential UNLOCK, or vice-versa while moving may cause the vehicle to unexpectedly handle differently. This could distract the operator and increase the risk of losing control and an accident.

HOW TO AVOID THE HAZARD

Always stop the vehicle before changing from 2WD to 4WD or from 2WD to 2WD-Differential UNLOCK.

4-12 Control Functions

On-Command four-wheel-drive switch “2WD/4WD”

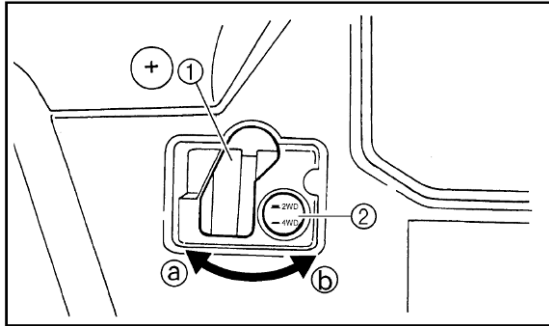

1. Select lever
2. On-Command four-wheel-drive switch “2WD/4WD”

To change from 2WD to 4WD, stop the vehicle, and then set the switch to “4WD”. When the vehicle is in 4WD, the 4WD indicator will come on in the multi-function meter unit display. To change from 4WD to 2WD, stop the vehicle, be sure

the select lever is set to position (a), and then set the switch to “2WD”.

On-Command Differential Gear Lock Switch “4WD”/“LOCK”

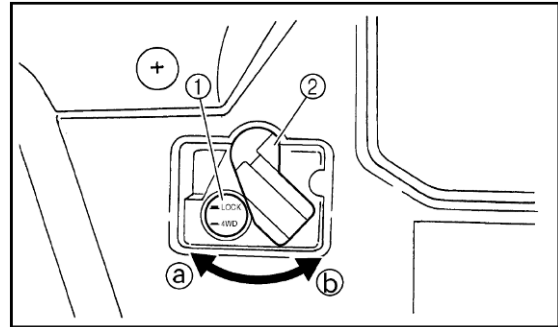

1. On-Command differential gear lock switch “4WD”/“LOCK”
2. Select lever

To lock the differential gear in 4WD, stop the vehicle, make sure the On-Command four-wheel-drive switch is set to “4WD”, move the select lever to position (b), and then

set the switch to “LOCK”. When the differential gear is locked, the differential gear lock indicator light will come on along with the differential gear lock indicator in the multifunction meter unit display. To release the differential gear lock, stop the vehicle and set the switch to “4WD”.

 **WARNING**

POTENTIAL HAZARD

Riding too fast while the vehicle is in 4WD-LOCK.

WHAT CAN HAPPEN

All wheels turn at the same speed when the differential is locked, so it takes more effort to turn the vehicle. The amount of effort required is greater the faster you go. You may lose control and have an accident if you cannot make a sharp enough turn for the speed you are traveling.

HOW TO AVOID THE HAZARD

Always ride at a slow speed when the vehicle is in 4WD-LOCK, and allow extra time and distance for maneuvers.

NOTE:

- When the switch is set to “LOCK”, the differential gear lock indicator and indicator light will flash until the differential gear is locked.
- When the indicator and indicator light are flashing, turning the steering wheel back and forth will help the differential gear lock to engage.
- Riding before the differential gear lock is properly engaged (e.g., when the indicator and indicator light are flashing)

4-14 Control Functions

will cause the engine speed to be limited until engagement is complete.

Accelerator pedal

Press the accelerator pedal down to increase engine speed. Spring pressure returns the pedal to the rest position when released. Always check that the accelerator pedal returns normally before starting the engine.

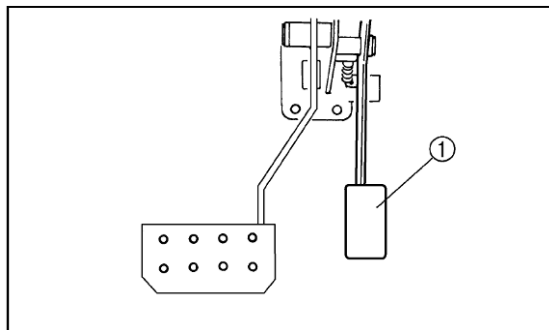

1. Accelerator pedal

Before starting the engine, check the accelerator pedal to be sure it is operating smoothly. Make sure the accelerator pedal fully returns to the idle position as soon as it is released.

Brake pedal

Press the brake pedal to slow or stop the vehicle.

⚠ WARNING

POTENTIAL HAZARD

Malfunction of the accelerator pedal.

WHAT CAN HAPPEN

A faulty pedal that makes it difficult to speed up or slow down could cause loss of control.

HOW TO AVOID THE HAZARD

Check the operation of the accelerator pedal before you start the engine .If it does not work smoothly, check for the cause. Correct the problem before operating the vehicle. Consult a service center if you cannot find or solve the problem yourself.

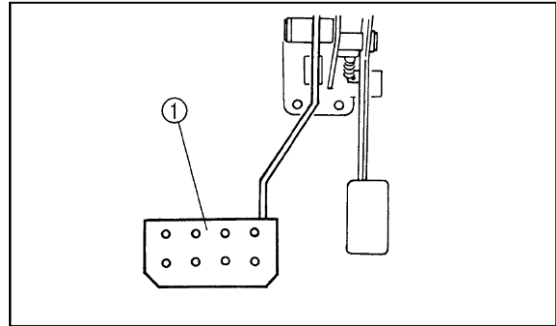

1. Brake pedal

Parking brake lever

The parking brake lever is located at the right side of the driver's seat. It will help keep the vehicle from moving while parked.

To set the parking brake, pull the lever up completely.

To release the parking brake, pull up on the

4-16 Control Functions

lever, press the release button, and then push the lever all the way down. Spring pressure helps return the lever to the released position. Be sure to fully release the parking brake before starting out, Failure to do so may result in poor performance and premature wearing of the rear brake and V-belt.

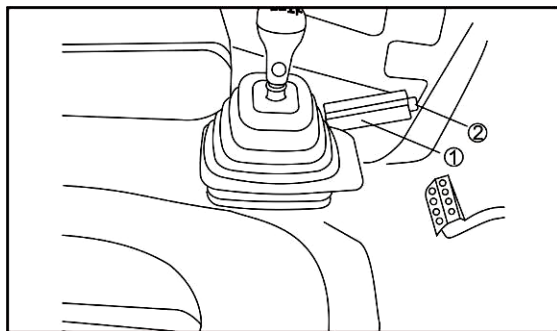

1. Parking brake lever 2. Release button

Drive select lever

The drive select lever is used to shift you vehicle into the low, high, neutral and reverse positions. (Refer to pages 6-4—6-6 for the drive select lever operation.)

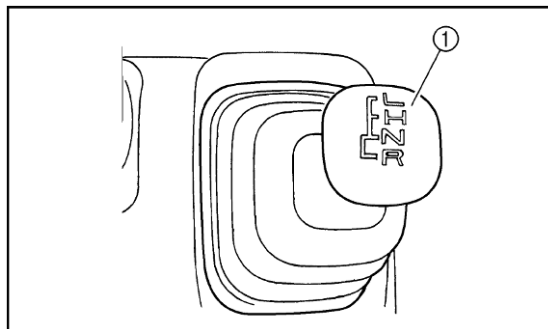

1. Drive select lever

Fuel tank cap

Remove the fuel tank cap by turning it counterclockwise.

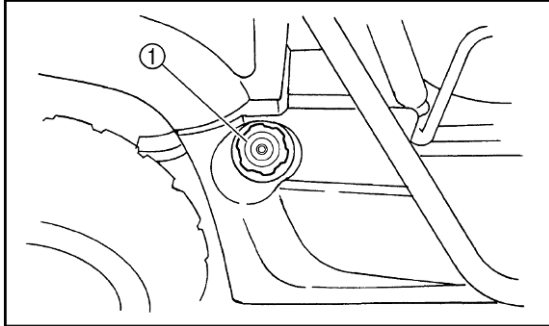

1. Fuel tank cap

Seats

To remove a seat, pull its seat lock lever upward, lift the front of the seat, and then slide the seat forward and up.

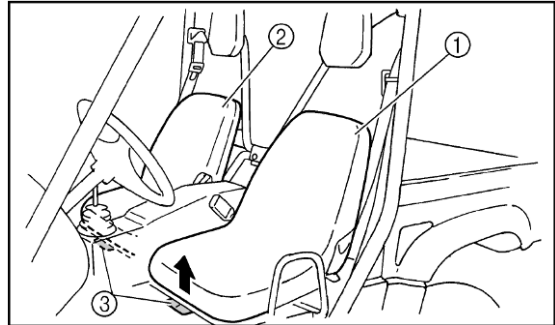

1. Driver seat

2. Passenger seat

3. Seat lock lever (x2)

4-18 Control Functions

To install a seat, insert the projection on the rear of the seat into the seat holders and push down on the seat at the front.

WARNING

POTENTIAL HAZARD

A loose seat.

WHAT CAN HAPPEN

The operator could lose control or the operator or passenger could fall if the seat is loose during operation.

HOW TO AVOID THE HAZARD

Make sure the seat is securely latched.

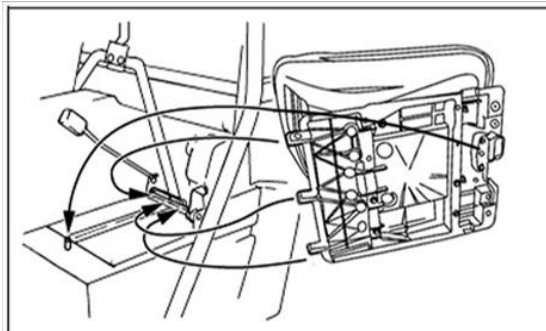

Seat belts

This vehicle is equipped with three-point seat belts for both the operator and passenger. Always wear the seat belt while riding in the vehicle.

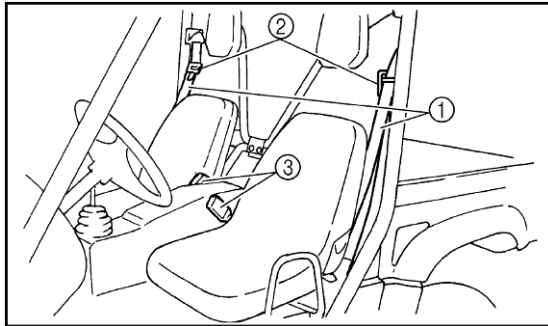

- 1. Seat belt (x2)
- 2. Latch plate (x2)
- 3. Buckle (x2)

To wear the seat belt properly, do the following:

1. Hold the latch plate as you pull the belt across your lap and chest. Make sure the belt is not twisted and is not caught on any portion of the vehicle, your clothing, or any equipment you are carrying.

2. Push the latch plate into the buckle until it clicks. Pull up on the latch plate to make sure it is secure.

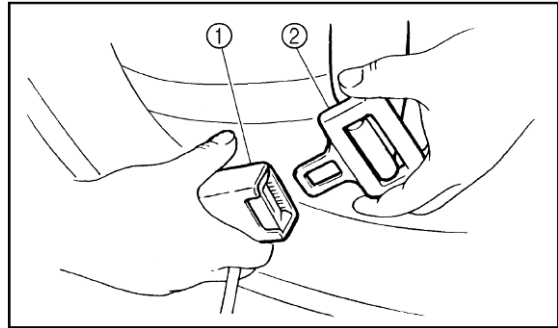

- 1. Buckle
- 2. Latch plate

3. Put the lap portion of the belt low on your hips. Push down on the buckle end of the belt as you pull up on the shoulder part so the belt is snug across your hips.
4. Position the shoulder belt over your shoulder and across your chest. The

4-20 Control Functions

shoulder belt should fit against your chest. If it is loose, pull the belt out all the way and then let it retract.

5. To release the buckle, firmly press the release button.

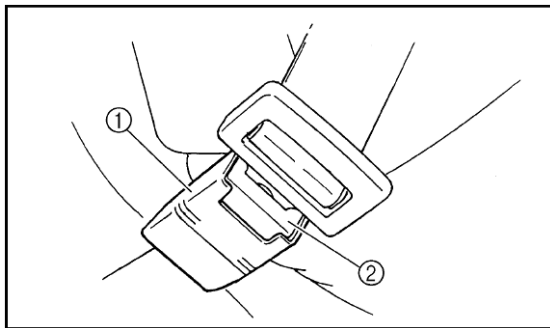

1. Buckle

2. Release button

WARNING

POTENTIAL HAZARD

Not wearing the seat belt or wearing the seat belt improperly.

WHAT CAN HAPPEN

There is increased risk of being killed or seriously injured in an accident.

HOW TO AVOID THE HAZARD

Always wear your seat belt when riding in the vehicle.

Be sure the seat belt is close fitting across your hips and chest and is latched securely.

Glove compartment

CAUTION:

To protect from damage, do not put metal products, like tools or sharply edged products directly in the glove compartment. If they must be stored, wrap them in appropriate cushion material.

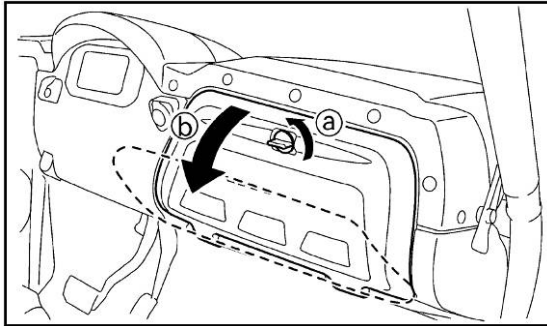

a. Unlock

b. Open.

Cargo bed

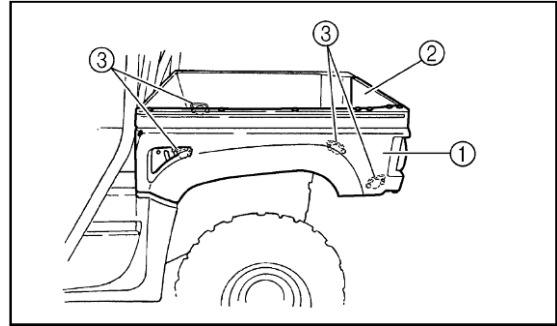

1. Cargo bed

2. Tailgate

3. Cargo hook(x4)

4-22 Control Functions

Opening and closing the tailgate

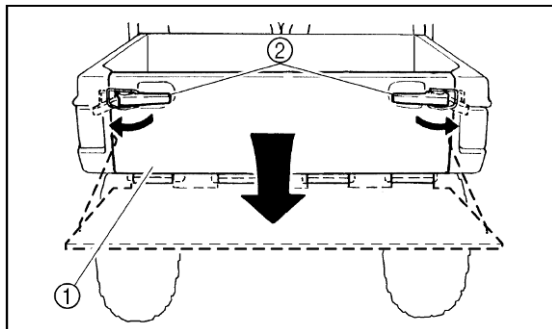

1. Tailgate

2. Latch (x2)

To open

Unhook the latches, and then lower the tailgate.

To close

Place the tailgate in the original position, and then hook the latches.

Lifting and lowering the cargo bed

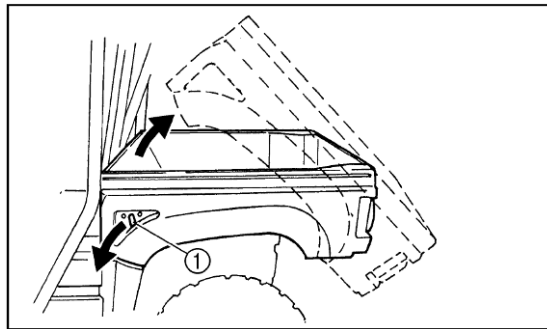

1. Cargo bed release lever

To lift

Push down cargo bed release lever on left or right side of the vehicle; slowly lift up cargo bed until it stops.

To lower

Lower cargo bed slowly to its original position and be sure it locks into place.

Maximum load limit: 350lb (159kg)

⚠ WARNING

POTENTIAL HAZARD

Pinch points.

WHAT CAN HAPPEN

You or someone else could be pinched between the cargo bed and the frame when the bed is being lowered.

HOW TO AVOID THE HAZARD

Before closing the bed, be sure others are standing away from the vehicle. Keep hands and fingers away from the pinch points between the bed and the frame.

⚠ WARNING

POTENTIAL HAZARD

Overloading the cargo bed

WHAT CAN HAPPEN

Could cause changes in vehicle handling which could lead to an accident.

HOW TO AVOID THE HAZARD

Never exceed the stated maximum load limit for this cargo bed.

Cargo should be properly distributed and securely attached.

Reduce speed when carrying cargo.

Allow greater distance for braking.

 **WARNING**

POTENTIAL HAZARD

Carrying a passenger in the cargo bed

WHAT CAN HAPPEN

The passenger could fall, be thrown out, or be struck by objects in the cargo bed.

HOW TO AVOID THE HAZARD

Never carry a passenger in the cargo bed.

This cargo bed is designed to carry cargo only.

Front and Rear Shock Adjustment(Option 1)

The spring preload can be adjusted to suit the operating conditions.

You can reduce preload for a softer ride, or increase preload if frequent bottoming out of the UTV occurs.

CAUTION: _____

Frequent or severe bottoming out of the UTV can cause increased wear or damage to the vehicle.

Adjust the spring preload as follows.

To increase the spring preload, turn the adjusting ring in direction **Ⓐ**.

To decrease the spring preload, turn the adjusting ring in direction **Ⓑ**.

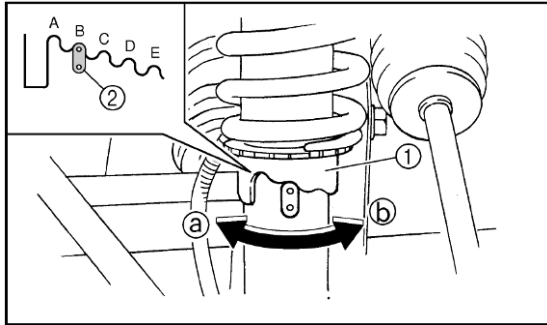

1. Spring preload adjusting ring
2. Position indicator

NOTE:

A special wrench can be obtained at a service center to make this adjustment.

Standard position: B
A-Minimum(soft)
E-Maximum(hard)

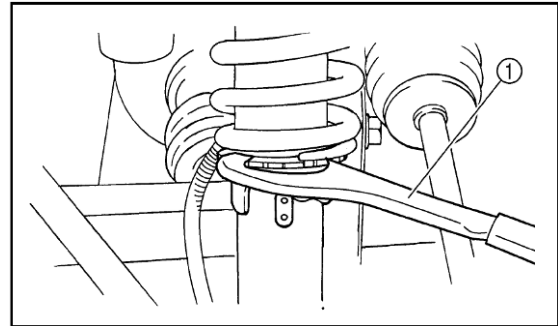

1. Special wrench

 **WARNING**

POTENTIAL HAZARD

Improper shock absorber adjustment.

WHAT CAN HAPPEN

Uneven adjustment can cause poor handling and loss of stability, which could lead to an accident.

HOW TO AVOID THE HAZARD

Always adjust the shock absorbers on the left and right side to the same setting.

Front and Rear Shock Adjustment(Option 2)

 **WARNING**

These shock absorber assemblies contain highly pressurized nitrogen gas, read and understand the following information before handling the shock absorber assemblies.

- Do not tamper with or attempt to open the cylinder assemblies.
- Do not subject the shock absorber assemblies to an open flame or other high heat source. This may cause the unit to explode due to excessive gas pressure.
- Do not deform or damage the cylinders in any way. Cylinder damage will result in poor damping performance.

• **Do not dispose of a damaged or worn out shock absorber assembly yourself. Take the shock absorber assembly to a HSUN dealer for any service.**

The spring preload, rebound damping and compression damping forces of the front and rear shock absorber assemblies can be adjusted to suit the operating conditions.

NOTE: _____
Never turn an adjusting mechanism beyond the minimum and maximum settings.

Spring preload

1. Loosen the locknut.
2. Turn the spring preload adjusting nut in direction (a) to increase the spring preload and thereby harden the suspension, and in direction (b) to decrease the spring preload and thereby soften the suspension.

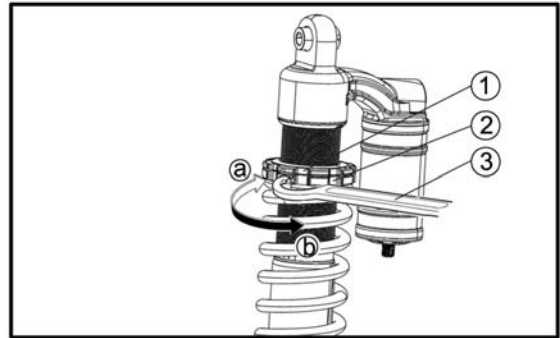

1. Locknut
2. Spring preload adjusting nut
3. Special wrench

4-28 Control Functions

- A special wrench can be obtained at a HSUN dealer to make this adjustment.
- The spring preload setting is determined by measuring distance A, shown in the illustration. The shorter distance A is, the lower the spring preload; the longer distance A is, the higher the spring preload. With each complete turn of the adjusting nut.

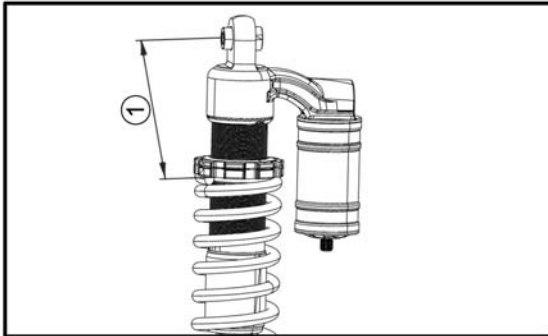

1. Distance A

Spring travel setting(Front)

Minimum(soft): 412mm(16.22 in)

Maximum(hard): 426mm(16.77 in)

Spring travel setting(Rear)

Minimum(soft): 330mm(12.99in)

Maximum(hard): 430mm(16.93 in)

3. Tighten the locknut.

NOTE:

Always tighten the locknut against the adjusting nut, and then tighten it to the specified torque.

Rebound damping force

Turn the rebound damping force adjusting screw in direction **S** to increase the rebound damping force and thereby harden the

damping, and in direction **F** to decrease the rebound damping force and thereby soften the damping.

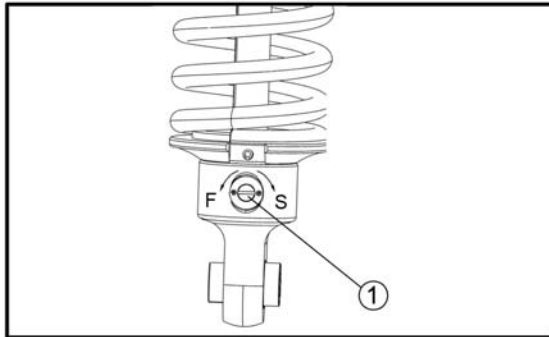

1.Rebound damping force adjusting screw

Compression damping force

Turn the compression damping force adjusting screw (use 3.0 allen wrench) in direction **a** to increase the compression damping force and thereby harden the damping, and in direction **b** to decrease the compression damping force and thereby soften the damping.

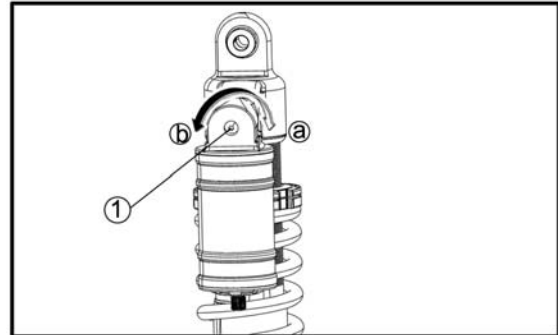

a) Compression damping force adjusting screw

WARNING

- **Suspension components become hot during operation. Never touch the compression damping force adjusting screw, the rebound damping force adjusting screw or the oil reservoir with your bare hand or skin until suspension components have cooled.**
- **Always adjust the shock absorber assemblies on the left and right side to the same setting. Uneven adjustment can cause poor handling and loss of stability, which could lead to an accident.**

Trailer hitch bracket

This vehicle is equipped with a 1 ¼ in receiver bracket for a standard trailer hitch. Trailer towing equipment can be obtained at a service center. (See pages 6-12 - 6-14 for precaution information.)

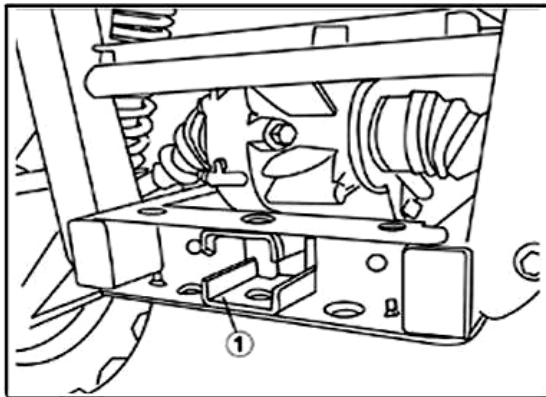

1. Trailer hitch bracket

Auxiliary DC jack

The auxiliary DC jack is located at the right side of the front panel. The auxiliary DC jack can be used for suitable work lights, radios, etc. The auxiliary DC jack should only be used when the engine is running.

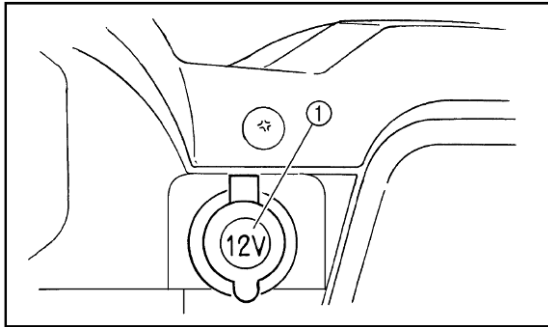

1. Auxiliary DC jack cap

1. Set the light switch to "OFF".
2. Start the engine. (See pages 6-1 - 6-3.)
3. Open the auxiliary DC jack cap, and then insert the accessory power plug into the

jack.

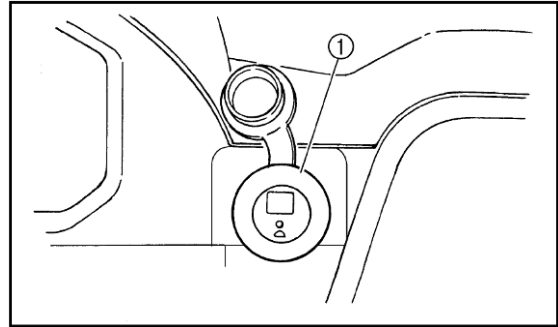

1. Auxiliary DC jack

Maximum rated capacity for the auxiliary DC jack:

DC 12V, 120W (10 A)

4-32 Control Functions

4. When the auxiliary DC jack is not being used, cover it with the cap.

CAUTION:

- Do not use accessories requiring more than the above maximum capacity. This may overload the circuit and cause the fuse to blow.
 - If accessories are used without the engine running or with the headlights turned on, the battery will lose its charge and engine starting may become difficult.
 - Do not use an automotive cigarette lighter or other access with a plug that gets hot because the jack can be damaged.
-

Before using this vehicle, check the following items:

ITEM	ROUTINE	PAGE
Brakes	<ul style="list-style-type: none"> ● Check operation, free play, fluid level and fluid leakage ● Fill with DOT 3 brake fluid if necessary 	5-2 - 5-3, 8-32
Parking brake	<ul style="list-style-type: none"> ● Check for proper operation, condition and free play 	6-8 - 6-9
Fuel	<ul style="list-style-type: none"> ● Check fuel level ● Fill with fuel if necessary 	5-4 - 5-5
Engine/Gear box oil	<ul style="list-style-type: none"> ● Check oil level ● Fill with oil if necessary 	5-5
Coolant reservoir	<ul style="list-style-type: none"> ● Check coolant level ● Fill with coolant if necessary 	5-6, 8-19 - 8-20
Final gear oil / Differential gear oil	<ul style="list-style-type: none"> ● Check for leakage 	5-7
Accelerator pedal	<ul style="list-style-type: none"> ● Check for proper accelerator pedal operation 	5-8
Seat belts	<ul style="list-style-type: none"> ● Check for proper operation and belt wear 	5-10
Steering	<ul style="list-style-type: none"> ● Check for proper operation 	5-10
Fittings and fasteners	<ul style="list-style-type: none"> ● Check all fittings and fasteners 	5-11
Lights and switches	<ul style="list-style-type: none"> ● Check for proper operation 	5-11
Wheels and tires	<ul style="list-style-type: none"> ● Check tire pressure, wear and damage 	5-11 - 5-13, 8-40 - 8-41
Axle boots	<ul style="list-style-type: none"> ● Check for damage 	8-20
Instrument	<ul style="list-style-type: none"> ● Check for complete and correct display 	4-2 - 4-8
Light/Indicator	<ul style="list-style-type: none"> ● Check for light / indicator operation 	4-2 - 4-8

5-2 Pre Operation Checks

WARNING

POTENTIAL HAZARD

Failure to inspect the vehicle before operating. Failure to properly maintain the vehicle.

WHAT CAN HAPPEN

Increases the possibility of an accident or equipment damage.

HOW TO AVOID THE HAZARD

Always inspect your vehicle each time you use it to make sure the vehicle is in safe operating condition. Always follow the inspection and maintenance procedures and schedules described in the Owner's Manual.

Brakes

Check for correct brake pedal free play. If the brake pedal free play is incorrect, have a service center adjust it. (See pages 8-34 - 8-35.)

Check the operation of the brake pedal. It should move smoothly and there should be a firm feeling when the brakes are applied. If not, have the vehicle inspected by a service center.

Brake fluid level

Check the brake fluid level. Add fluid if necessary. (See pages 8-32)

Recommended brake fluid: DOT 3

Brake fluid leakage

Check to see if any brake fluid is leaking out of the pipe joints or the brake fluid reservoir. Apply the brakes firmly for one minute. If there is any leakage, have the vehicle inspected by a service center.

Brake operation

Test the brakes at slow speed after starting out to make sure they are working properly. If the brakes do not provide proper braking performance, inspect the brake system. (See pages 8-30 - 8-35.)

 **WARNING****POTENTIAL HAZARD**

Driving with improperly operating brakes.

WHAT CAN HAPPEN

You could lose braking ability which could lead to an accident.

HOW TO AVOID THE HAZARD

Always check the brakes at the start of every ride. Do not operate the vehicle if you find any problem with the brakes. If a problem cannot be corrected by the adjustment procedures provided in this manual, have the vehicle inspected by a service center.

5-4 Pre Operation Checks

Fuel

Make sure there is sufficient gasoline in the tank.

Recommended fuel:

Unleaded gasoline only

Fuel tank capacity:

7.4 gal (28L)

CAUTION:

Use only unleaded gasoline. The use of leaded gasoline will cause severe damage to internal engine parts, such as the valves and piston rings, as well as to the exhaust system.

Your engine has been designed to use regular unleaded gasoline with a pump octane number $([R+M] / 2)$ of 91 or higher, or research octane number of 91 or higher. If knocking or pinging occurs, use a different brand of gasoline or premium unleaded fuel. Unleaded fuel will give you longer spark plug life and reduced maintenance cost.

Gasohol

The UTV uses an electric fuel injection system, and its emissions completely meet the requirements of relevant rule of the United States. Mixed fuel is forbidden to use on the UTV. Mixed fuel will cause engine to work abnormally and cause deterioration.

 **WARNING**

POTENTIAL HAZARD

Improper care when refueling.

WHAT CAN HAPPEN

Fuel can spill, which can cause a fire and severe injury. Fuel expands when it heats up. If the fuel tank is overfilled, fuel could spill out due to heat from the engine or the sun.

HOW TO AVOID THE HAZARD

Do not overfill the fuel tank. Be careful not to spill fuel, especially on the engine or exhaust pipe. Wipe up any spilled fuel immediately. Be sure the fuel tank cap is closed securely.

Engine oil

Make sure the engine oil is at the specified level. Add oil as necessary. (See pages 8-10)

CAUTION: _____

- In order to prevent clutch slippage (since the engine oil also lubricates the clutch), do not mix any chemical additives. Do not use oils with a diesel specification of “CD” or oils of a higher quality than specified. In addition, do not use oils labeled “ENERGYCONSERVING II” or higher.
 - Make sure that no foreign material enters the crankcase.
-

5-6 Pre Operation Checks

Recommended engine oil type and quantity:

See page 10-2

Coolant

Check the coolant level in the coolant reservoir when the engine is cold. (The coolant level will vary with engine temperature.) The coolant level is satisfactory if it is between the minimum and maximum level marks on the coolant reservoir. If the coolant level is at or below the minimum level mark, add additional coolant to bring the level up to maximum level mark. If coolant is not available, add distilled water. Change the coolant every two years. (See pages 8-19 - 8-20 for details)

CAUTION:

Hard water or salt water is harmful to the engine. You may use soft water if you cannot get distilled water.

Coolant reservoir capacity
(up to the maximum level mark):
0.37 qt, (0.35L)

⚠ WARNING

POTENTIAL HAZARD

Removing the radiator cap when the engine and radiator are still hot.

WHAT CAN HAPPEN

You could be burned by hot fluid and steam blown out under pressure.

HOW TO AVOID THE HAZARD

Wait for the engine to cool before removing the radiator cap. Always use a thick rag over the cap. Allow any remaining pressure to escape before completely removing the cap.

Final gear oil

Make sure the final gear oil is at the specified level. Add oil as necessary. (See pages 8-14 - 8-15 for details)

Recommended oil:

SAE 80 API GL-4 Hypoid gear oil

If desired, an SAE 80W90 hypoid gear oil may be used for all conditions.

NOTE:

GL-4 is a quality and additive rating, GL-5 or GL-6 rated hypoid gear oils may also be used.

Differential gear oil

Make sure the differential gear oil is at the specified level. Add oil as necessary. (See pages 8-17 - 8-18 for details.)

5-8 Pre Operation Checks

WARNING

Failure to check or maintain proper operation of the throttle system can result in an accident and lead to serious injury or death if the throttle pedal sticks during operation.

Never start or operate this vehicle if it has a sticking or improperly operating throttle pedal.

Immediately contact your service center for service if throttle problems arise.

Always check the pedal for free movement and return before starting the engine and occasionally during operation.

Recommended oil:

SAE 80 API GL-5 Hypoid gear oil

Throttle Pedal

Check to see that the accelerator pedal operates correctly. It must operate smoothly and fully spring back to the idle position when released. Have a service center repair as necessary for proper operation.

Throttle Freeplay

If the throttle pedal has excessive play due to cable stretch or mis-adjustment, it will cause a delay in throttle response, especially at low engine speed. The throttle may also not open fully. If the throttle pedal has no freeplay, the throttle may be hard to control, and the idle speed may be erratic. Check the throttle pedal freeplay. Adjust the freeplay if necessary.

Throttle Freeplay Inspection

1. Lift the parking brake to the top to park the car.
2. Apply the brakes. Start the engine. Allow it to warm up thoroughly.
3. Measure the distance the throttle pedal moves before the engine begins to pick up speed. Freeplay should 1/16 to 1/8 inches (1.5-3mm).

Throttle Freeplay Adjustment

1. Remove both seats. Remove the middle cover of the engine. (see PAGE 8-9)
2. Loosen the nut of throttle cable on the valve,
Spin the throttle cable inside/ outside to increase the throttle pedal's moving distance to 1.5-3 mm.

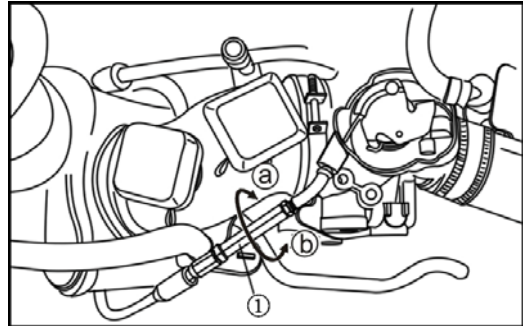

1. Accelerator Cable column nut
3. Tighten the the nut.

5-10 Pre Operation Checks

4. Resume the center cover and seat to their position

Steering Wheel Inspection

Check the steering wheel for specified freeplay and smooth operation.

1. Position the vehicle on level ground.
2. Lightly turn the steering wheel left and right.
3. There should be 0.8" -1.0" (20-25 mm) of freeplay.

If there is excessive freeplay, strange noises, or the steering feels rough or "catchy," have the steering system inspected by an authorized service center.

Seat belts

Make sure that both seat belts are not frayed or damaged. The seat belt must move smoothly

when pulled out and retract on its own when released. The latch plate should click securely into the buckle and release when the release button is pushed firmly. Wash off any dirt or mud which could affect operation. Have a service center repair as necessary for proper operation.

Fittings and fasteners

Always check the tightness of chassis fittings and fasteners before a ride. Take the vehicle to a service center or refer to the Service Manual for correct tightening torque.

Lights

Check the headlights and tail/brake lights to make sure they are in working condition. Repair

as necessary for proper operation.

Switches

Check the operation of all switches. Have a service center repair as necessary for proper operation.

Tires

 WARNING

POTENTIAL HAZARD
Operating this vehicle with improper tires, or with improper or uneven tire pressure.

WHAT CAN HAPPEN
Use of improper tires on this vehicle, or operation of this vehicle with improper or uneven tire pressure, may cause loss of control, increasing your risk of accident.

HOW TO AVOID THE HAZARD

1. The tires should be set to the recommended pressure:

- Front 14psi (100kpa ,1.02 kgf/cm²)
- Rear 16psi (110kpa ,1.12 kgf/cm²)

Check and adjust tire pressures when the tires are cold.

Tire pressures must be equal on both sides.

5-12 Pre Operation Checks

2. Tire pressure below the minimum specified could cause the tire to dislodge from the rim under severe riding conditions.

3. Use no more than the following pressures when seating the tire beads.

Higher pressures may cause the tire to burst.

Inflate the tires very slowly and carefully. Fast inflation could cause the tire to burst.

How to measure tire pressure

Use the tire pressure gauge.

NOTE: _____

The tire pressure gauge is included as standard equipment. Make two measurements of the tire pressure and use the second reading. Dust or dirt in the gauge could cause the first reading to

be incorrect.

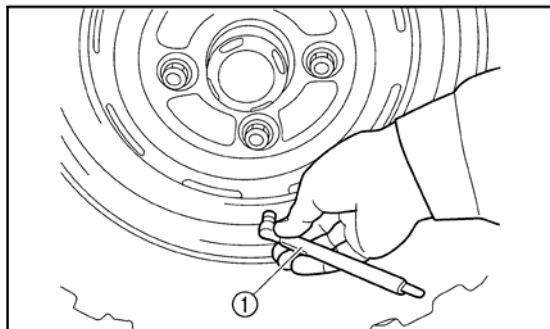

1. Tire pressure gauge

Tire wear limit

When the tire groove decreases to 0.12 in (3 mm) due to wear, replace the tire.

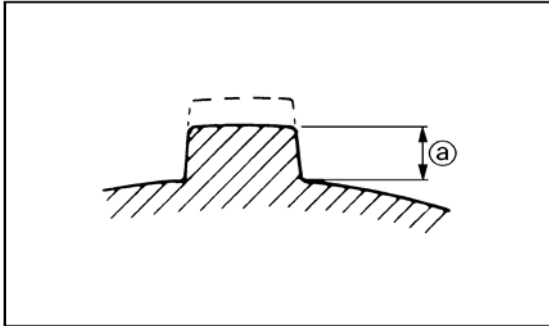

a. Tire wear limit

⚠ WARNING

POTENTIAL HAZARD

Operating vehicle without being familiar with all controls.

WHAT CAN HAPPEN

Loss of control, which could cause an accident or injury.

HOW TO AVOID THE HAZARD

Read the Owner's Manual carefully. If there is a control or function you do not understand, ask your service center.

⚠ WARNING

POTENTIAL HAZARD

Freezing control cables due to cold weather conditions.

WHAT CAN HAPPEN

Loss of vehicle control, which could lead to an accident or collision.

HOW TO AVOID THE HAZARD

When riding in cold weather, always make sure all control cables work smoothly before you begin riding.

1. Check the throttle cable, parking cable, and the reverse lock out cable, and make sure that they are not frozen.
2. Start the engine (see P6-2).

Starting the engine in low temperatures

Starting the Engine

CAUTION:

See the “Engine Break-In” section prior to operating the engine for the first time.

1. Turning the key to “ON”, the light in the display will turn on, and electronic injection system’s fuel pump will start to work; wait for 10 second before the following operation.
2. Apply the brake.
3. Shift the drive select lever into the neutral position.

NOTE:

- When the drive select lever is in the neutral position “N”, the neutral indicator light should come on. If the neutral indicator light does not come on, ask a

service center to inspect the electric circuit.

- The engine can be started in any gear if the brake is applied. However, it is recommended to shift into neutral “N” before starting the engine.
-

4. With your foot off the accelerator pedal, start the engine by turning the key to “START”.

NOTE:

If the engine fails to start, release the key, and then try starting again. Wait a few seconds before the next attempt. Each cranking should be as short as possible to preserve battery energy. Do not crank the engine more than 5 seconds on each attempt.

6-3 Operation

5. Continue warming up the engine until it idles smoothly before riding.

WARNING

POTENTIAL HAZARD

Engine idle speed exceeds the regulated speed.

WHAT CAN HAPPEN

Will make it difficult to select the proper gear, which could lead to loss of control, causing serious injury or even death.

HOW TO AVOID THE HAZARD

Because of electronic injection system, the idle speed will be speed up when the voltage of battery is low.

Place the gear on position 'N', and press the throttle pedal to make the engine run at

2500RPM to charge the battery for 5-10 minutes; when the voltage of battery is over 12V, the idle speed will be normal. If the idle speed is still high, please contact your service center.

Warming Up

To get maximum engine life, always warm up the engine before driving. Never accelerate hard with a cold engine! To see whether or not the engine is warm, check if it responds to the throttle normally.

1. Release the brakes and press the accelerator pedal gradually.
2. If the rotation rate of the engine accelerates with pedal steadily, the warming-up procedure has been ready and the vehicle can be ridden.

Otherwise, go on with the third step.

3. Continue warming up the engine until it idles smoothly.

CAUTION: _____

See the “Engine break-in” section prior to operating the engine for the first time.

Drive Select Lever Operation and Driving In Reverse

CAUTION: _____

Before shifting, you must stop the UTV and return the throttle lever to the closed position; otherwise the transmission may be damaged.

Shifting: Neutral to High and High to Low

1. Stop the vehicle. Keep your foot off the accelerator pedal.
2. Apply the brakes, and then shift by moving the drive select lever along the shift guide.

NOTE: _____

Make sure that the drive select lever is completely shifted into position.

6-5 Operation

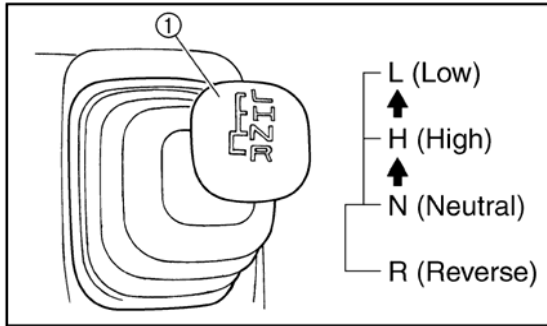

1. Drive select lever

3. Release the brakes and press the accelerator pedal gradually.

Shifting: Neutral to Reverse

1. Stop the vehicle. Keep your foot off the accelerator pedal.
2. Apply the brake pedal.
3. Shift from neutral to reverse or vice versa by moving the drive select lever along

the shift guide.

NOTE:

- Please kick the brake pedal first, before place gearshifts lever to “reverse” position.
- In the brake pedal, there is a cable, which is connected to a position pin located on the gearshift assembly. Only when the brake pedal is depressed, the position pin will be retracted, and gearshifts can be removed to “reverse” position.

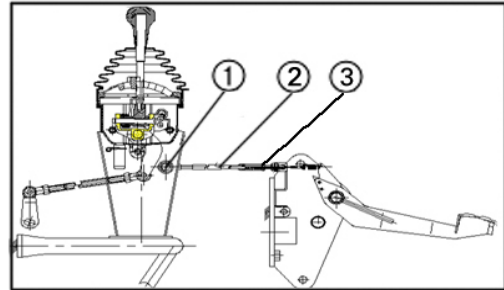

1.Position pin

2.Cadle

3. Adjust

until the vehicle starts moving.

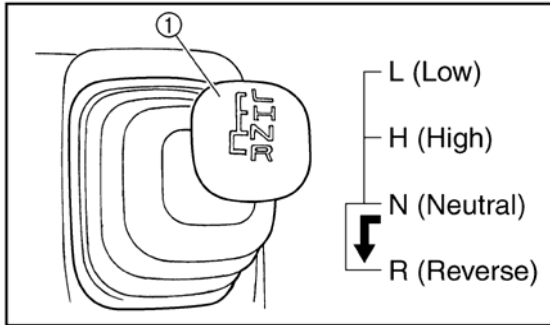

1. Drive select lever

NOTE:

- When in reverse, the reverse indicator light should be on. If the light does not come on, ask a service center to inspect the reverse indicator light electrical circuit.
- Due to the synchronizing mechanism in the engine, the light may not come on

4. Check behind for people or obstacles, and then release the brake pedal.
5. Press the accelerator pedal gradually and continue to watch to the rear while backing up.

⚠ WARNING

POTENTIAL HAZARD

Parking on a hill or other incline.

WHAT CAN HAPPEN

The vehicle could roll out of control, increasing the chance of an accident.

HOW TO AVOID THE HAZARD

Avoid parking on hills or other inclines. If you must park on an incline, apply the parking brake, and block the front and rear wheels with rocks or other objects. Never park the vehicle on hills that are too steep.

⚠ WARNING

POTENTIAL HAZARD

Improperly operating in reverse.

WHAT CAN HAPPEN

You could hit an obstacle or person behind you, resulting in serious injury.

HOW TO AVOID THE HAZARD

When you shift into reverse, make sure there are no obstacles or people behind you. When it is safe to proceed, go slowly.

Parking

- a) When parking, stop the engine and shift the drive select lever into the neutral position.
- b) Push the brake pedal down, and pull the parking brake to top position to park the vehicle

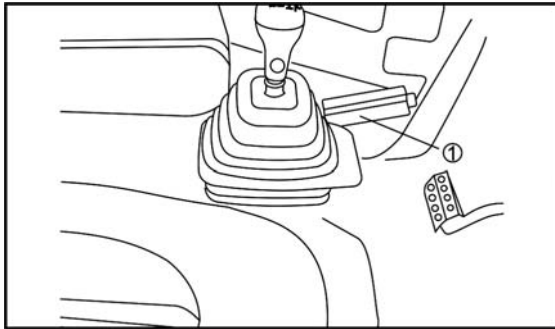

1. Parking handbar

Parking on a Slope

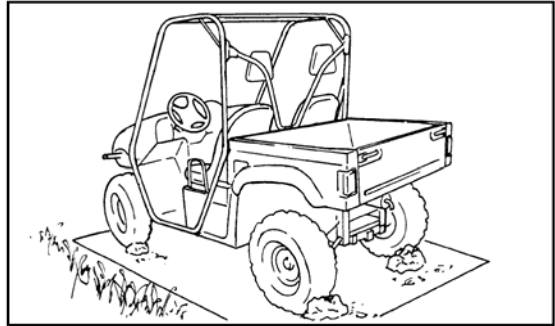

1. Bring the vehicle to a stop by applying the brakes.
2. Stop the engine.
3. With the brakes applied, set the parking brake.

6-9 Operation

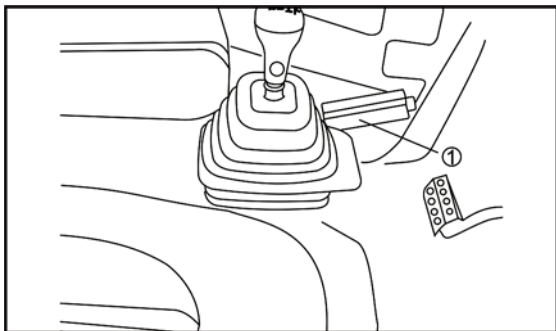

1. parking handbar

NOTE: _____

Like many other vehicles, the parking brake acts on the rear wheels. For the parking brake to operate all four wheels, shift to 4WD before stopping the engine.

The buzzer will keep buzzing if the park is on when driving.

Vehicle Break-in Period

The break-in period for your new UTV vehicle is the first 25 hours of operation, or the time it takes to use the first three tanks full of gasoline. No single action on your part is as important as a proper break-in period. Careful treatment of a new engine and drive components will result in more efficient performance and longer life for these components. Perform the following procedures carefully.

CAUTION: _____

- Excessive heat build-up during the first three hours of operation will damage close-fitted engine parts and drive components. Do not operate at full throttle or high speeds during the first three hours

of use.

- Use of any engine oil not mentioned in this manual will cause severe damage to the engine.
-

Engine Break-In

There is never a more important period in the life of your vehicle than the period between 0 and 25 hours. For this reason, we ask that you carefully read the following material.

Because the engine is brand new, you must not put an excessive load on it for the first several hours of running.

During the first 25 hours, the various parts in the engine wear and polish themselves to the correct operating clearances. During this period, prolonged full throttle operation or any condition which might result in excessive engine heating must be avoided. However,

momentary (2-3 seconds maximum) full throttle operation under load does not harm the engine.

Each full throttle acceleration sequence should be followed with a substantial rest period for the engine by cruising at lower r/min so the engine can rid itself of the temporary build up of heat. If any abnormality is noticed during this period, consult a service center.

0-10 Hours:

Avoid continuous operation above half throttle. Allow a cooling off period of five to ten minutes after every hour of operation. Vary the speed of the vehicle from time to time. Do not operate it at one set throttle position.

6-11 Operation

10-25 Hours:

Avoid prolonged operation above 3/4 throttle. Rev the vehicle freely but do not use full throttle at any time.

After break-in:

The vehicle can now be operated normally.

Brake System Break-in

Apply only moderate braking force for the first 50 stops. Aggressive or overly forceful braking when the brake system is new could damage brake pads and rotors.

CVT Break-in (Clutches/Belt)

A proper break-in of the clutches and drive belt will ensure a longer life and better

performance. Break in the clutches and belt by operating at slower speeds during the break-in period as recommended. Pull only light loads. Avoid aggressive acceleration and high speed operation during the break-in period.

Accessories

Accessories can affect the handling and control of your vehicle. Keep the following in mind when considering an accessory or operating a vehicle that has accessories.

- Choose only accessories designed for your vehicle. Your service center has a variety of genuine accessories. Other accessories may also be available on the market. However, it is not possible for to

test all nonstandard accessories, nor have any control over the quality or suitability of them. Choose a genuine accessory, or one that is equivalent in design and quality.

- Accessories should be rigidly and securely mounted. An accessory that can shift position or come off while you are operating could affect your ability to control the vehicle.
- Do not mount an accessory where it could interfere with your ability to control the vehicle. Examples include (but are not limited to) an object that limits your ability to turn the steering wheel or one that limits your view.
- Use extra caution when driving a vehicle

with accessories. The vehicle may handle differently than it does without accessories.

Loading

Cargo or a trailer can change the stability and handling of a vehicle. You must use common sense and good judgment when carrying cargo or towing a trailer. Keep the following points in mind:

- Never exceed the weight limits shown. An overloaded vehicle can be unstable.
- Choose a trailer hitch drawbar designed for use with a 1 ¼ in receiver.
- Do not exceed the maximum tongue weight. You can measure tongue weight with a bathroom scale. Put the tongue of

6-13 Operation

the loaded trailer on the scale with the tongue at hitch height. Adjust the load in the trailer, if necessary, to reduce the weight on hitch. If you are carrying cargo and towing a trailer, include the tongue weight in the maximum vehicle load limit

MAXIMUM LOADING LIMIT

- Vehicle loading limit (total weight of cargo, operator, passenger and accessories, and tongue weight): 880 lb (399Kg)
- Cargo bed: 350 lb (159Kg)
- Trailer hitch:
Pulling load (total weight of trailer and cargo): 1,200lb (544Kg)
Tongue weight (vertical weight on trailer hitch point): 110lb (50Kg)

- Load cargo in the cargo bed as close to the center of the vehicle as possible and tie it down using the cargo hooks equipped on the cargo bed.
- Tie down cargo securely in the trailer. Make sure cargo in the trailer cannot move around. A shifting load can cause an accident.
- Make sure the load does not interfere with controls or your ability to see where you are going.
- Drive more slowly than you would without a load. The more weight you carry, the slower you should go. Although conditions vary, it is good practice not to exceed low range whenever you are carrying heavier loads or when towing a

trailer.

- Allow more braking distance. A heavier vehicle takes longer to stop.
- Avoid making sharp turns unless at very slow speeds.
- Avoid hills and rough terrain. Choose terrain carefully. Added weight affects the stability and handling of the vehicle.

WARNING

POTENTIAL HAZARD

Overloading this vehicle or carrying or towing cargo improperly.

WHAT CAN HAPPEN

Could cause changes in vehicle handling which could lead to an accident.

HOW TO AVOID THE HAZARD

Never exceed the stated load capacity for this vehicle.

Cargo should be properly distributed and securely attached.

Reduce speed when carrying cargo or pulling a trailer. Allow greater distance for braking.

DRIVING YOUR VEHICLE

GETTING TO KNOW YOUR VEHICLE

This off-highway utility vehicle will handle and maneuver differently from an ordinary passenger car or other vehicle.

Before you begin to use your vehicle, be sure you have read this Owners Manual completely and understand all the features.

Pay particular attention to the safety information on pages 2-1 - 2-5. Please read all the caution and warning labels on your vehicle.

This vehicle is designed for the operator and one passenger. The driver and passenger must always wear a seat belt. Never carry passengers in the cargo bed.

WARNING

POTENTIAL HAZARD

Not wearing the seat belt.

Wearing the seat belt improperly.

WHAT CAN HAPPEN

There is increased risk of being killed or seriously injured in an accident.

HOW TO AVOID THE HAZARD

Always wear your seat belt when riding in the vehicle.

Be sure the seat belt is close fitting across your hips and chest and is latched securely.

⚠ WARNING

POTENTIAL HAZARD

Carrying a passenger in the cargo bed.

WHAT CAN HAPPEN

The passenger could fall or be struck by objects in the cargo bed.

HOW TO AVOID THE HAZARD

Never carry a passenger in the cargo bed.

The cargo bed is designed to carry cargo only.

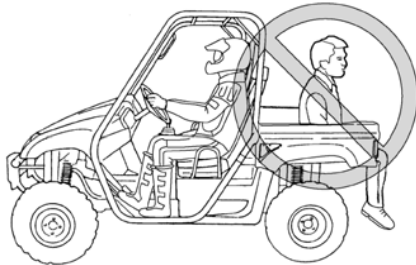

The total weight of operator, passenger, accessories, cargo, trailer tongue weight, and the vehicle itself must not exceed 2,400 lbs (1090Kg).

WARNING

POTENTIAL HAZARD

Overloading this vehicle or carrying or towing cargo improperly.

WHAT CAN HAPPEN

Could cause changes in vehicle handling which could lead to an accident.

HOW TO AVOID THE HAZARD

Never exceed the stated load capacity for this vehicle.

Cargo should be properly distributed and securely attached.

Reduce speed when carrying cargo or pulling a trailer. Allow greater distance for braking.

Always follow the instructions in your Owner's Manual for carrying cargo or pulling a trailer.

The driver and passenger must always wear a seat belt, an approved motorcycle helmet, eye protection and protective clothing, including over-the-ankle boots, gloves, a long-sleeved shirt or jacket, and long pants. Keep hands and feet inside the vehicle at all times.

⚠ WARNING

POTENTIAL HAZARD

Operating this vehicle without wearing an approved motorcycle helmet, eye protection, and protective clothing.

WHAT CAN HAPPEN

Operating without an approved motorcycle helmet increases your chances of a severe head injury or death in the event of an accident.

Operating without eye protection can result in an accident and increases your chances of a severe injury in the event of an accident.

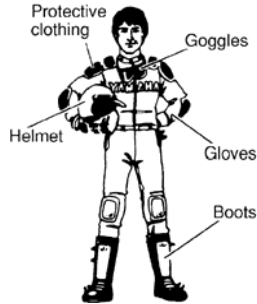

HOW TO AVOID THE HAZARD

Always wear an approved motorcycle helmet that fits properly. You should also wear:

- eye protection
(goggles or face shield)
- gloves
- boots
- long-sleeved shirt or jacket

long pants

7-5 Your Vehicle

LEARNING TO OPERATE YOUR VEHICLE

You should become familiar with the performance characteristics of the vehicle in a large, flat area that is free of obstacles and other vehicles. Practice control of the accelerator pedal, brakes, steering, and drive select lever. Drive at a slow speed and become comfortable at that speed before gradually increasing your speed. Become familiar with the way the vehicle feels in low and high ranges, first in two-wheel drive (2WD) and then in four-wheel drive (4WD) and four-wheel drive with the differential locked. Practice driving in reverse. Take the time to learn basic operation before attempting maneuvers that are more difficult.

Perform the Pre-Operation Checks on pages 5-1 - 5-11. Set the parking brake, shift to neutral, and follow the instructions on page 6-1 to start the engine. Once it has warmed up you are ready to begin driving your vehicle. With the engine idling, shift the drive select lever into low or high. Then release the parking brake. Press the accelerator pedal slowly and smoothly. The centrifugal clutch will engage and you will start to accelerate. Avoid higher speeds until you are thoroughly familiar with the operation of your vehicle. When slowing down or stopping, take your foot off the accelerator pedal and smoothly press the brake pedal. Improper use of the brakes can cause the tires to lose traction, reducing control and increasing the possibility of an accident.

CAUTION:

Do not shift from low to high or vice versa without coming to a complete stop and waiting for the engine to return to normal idle speed. Damage to the engine or drive train may occur.

TURNING YOUR VEHICLE

The vehicle is easier to steer in two-wheel drive (2WD) than four-wheel drive (4WD). Steering takes the most effort in 4WD with the differential locked.

It is possible for the vehicle to roll over or go out of control if you attempt sharp, high-speed turns. You should also be careful making sharp turns on rough terrain. Do not attempt to turn around or make abrupt

maneuvers on slope.

Position your hands on the steering wheel so that your thumbs and fingers do not wrap around the wheel. This is particularly important when driving in rough terrain. The front wheels will move right and left as they respond to the terrain, and this movement will be felt in the steering wheel. A sudden jolt could wrench the steering wheel around, and your thumbs or fingers could be injured if they are in the way of the steering wheel spokes.

7-7 Your Vehicle

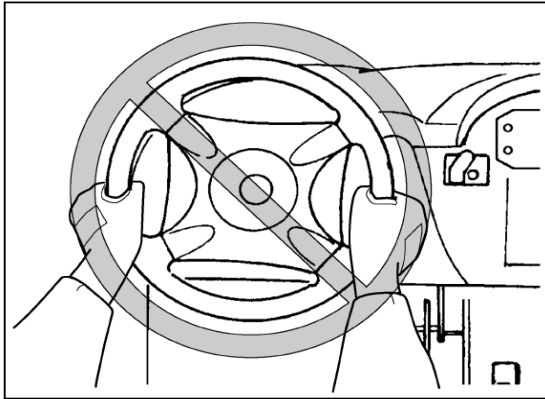

Operating Improperly in Reverse

Improperly operating in reverse could result in a collision with an obstacle or person. Always follow proper operating procedures.

Follow these precautions when operating in reverse:

1. Always check for obstacles or people behind the vehicle.
2. Apply the throttle lightly. Never open the throttle suddenly.
3. Back up slowly.
4. Apply the brakes lightly for stopping.
5. Avoid making sharp turns.

Before shifting into reverse gear, always check for obstacles or people behind the vehicle. When it is safe to proceed, back up slowly.

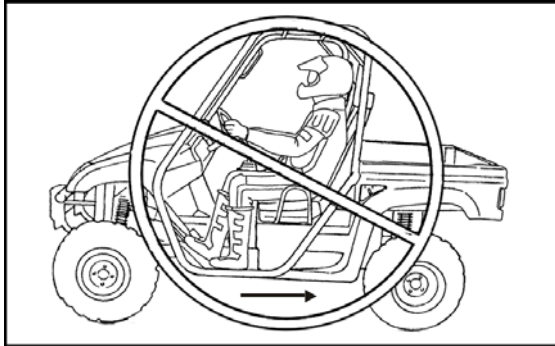

BRAKING

Braking ability is affected by the type of terrain. In most cases, gradual application of the brakes is more effective than abrupt braking, particularly on loose surfaces like gravel. Always allow for greater braking distance on rough, loose, or slippery surfaces.

GOING UPHILL

Do not attempt to climb hills until you have mastered basic maneuvers on flat ground. Use proper driving techniques to avoid overturns on hills and slopes. Drive straight up hills, and avoid crossing the side of a hill, which increases your chance of rollover. Practice first on gentle slopes before attempting steeper hills. Always check the terrain carefully before attempting any hill. Use common sense and remember that

7-9 Your Vehicle

some hills are too steep for you to climb.

Maximum slope angle:15°

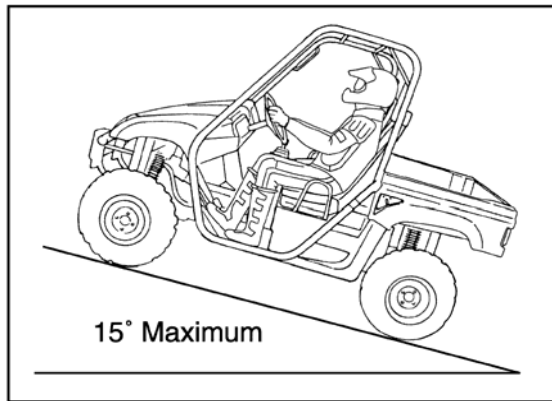

Choose carefully which hills you attempt to climb. Avoid hills with slippery surfaces or ones where you will not be able to see far enough ahead of you.

⚠ WARNING

POTENTIAL HAZARD

Operating on excessively steep hills.

WHAT CAN HAPPEN

The vehicle can over turn more easily on extremely steep hills than on level surfaces or small hills.

HOW TO AVOID THE HAZARD

Never operate your vehicle on hills too steep for it or your abilities. Never operate vehicles on hills steeper than 15° .

Do not drive across the face of a hill. Go straight up the hill.

Practice on smaller hills before attempting large hills.

Before climbing the hill, first be sure you are operating in low range 4WD or, if necessary, with 4WD. To climb a hill, you need traction, momentum, and steady throttle. Travel fast enough to keep your momentum going, but not so fast that you cannot react to changes in the terrain as you climb. Slow down when you reach the crest of the hill if you cannot clearly see what is on the other side-there could be another person, an obstacle, or a sharp drop off.

If you start to lose traction or momentum when climbing, and you decide you will be unable to continue, use the brakes to come to a stop. Do not attempt to turn the vehicle

around. With your foot on the brake, look behind you and plan your descent. Shift the drive select lever in reverse so you can use the engine brake if necessary to slow your descent. Release the brake and begin to coast down the hill. Use engine braking as much as possible, gently applying the brakes when necessary.

GOING DOWNHILL

Check the terrain carefully before going down a hill. When possible, choose a path that lets you drive your vehicle straight downhill. Avoid sharp angles that could allow the vehicle to pitch or roll over. Carefully choose your path and drive no faster than

7-11 Your Vehicle

you will be able to react to obstacles that may appear.

WARNING

POTENTIAL HAZARD

Going down a hill improperly.

WHAT CAN HAPPEN

Could cause loss of control or cause the vehicle to overturn.

HOW TO AVOID THE HAZARD

Always check the terrain carefully before you start down any hill. Never go down a hill at high speed. Avoid going down a hill at an angle that would cause the vehicle to lean sharply to one side. Go straight down the hill where possible.

Before starting downhill, make sure the vehicle is in low-range 4WD. On most slopes, this will let you use engine braking to help you go downhill slowly. Go as slowly as possible. If you pick up too much speed, apply the brakes gently. Avoid sudden application of the brakes, which could cause the vehicle to start sliding.

If you are sliding or skidding, try to steer in the direction the vehicle is sliding to help you regain control.

If you must turn on the hill to avoid an obstacle, do so slowly and carefully. If the vehicle starts to tip, gradually steer in the downhill direction if there are no obstacles in your path. As you regain proper balance, gradually steer again in the direction you want to go.

CROSSING THROUGH SHALLOW WATER

If you must cross shallow, slow moving water up to the depth of the vehicle's floorboards, choose your path carefully to avoid sharp drop-offs, large rocks, or slippery surfaces that could cause the vehicle to overturn.

Never operate through water deeper than 13 in (33 cm) or fast flowing water.

Wet brakes may have reduced effectiveness. After leaving the water, test your brakes. If necessary, apply the brakes several times to let friction dry out the linings.

 WARNING**POTENTIAL HAZARD**

Operating this vehicle through deep or fast-flowing water.

WHAT CAN HAPPEN

Loss of control, which could result in an accident including overturn, which could increase the risk of drowning.

HOW TO AVOID THE HAZARD

Never operate this vehicle in fast flowing water or in water deeper than 13 in (33cm).

Remember that wet brakes may have reduced stopping ability. Test your brakes after leaving water. If necessary, apply the brakes several times to let friction dry out the linings.

7-13 Your Vehicle

CAUTION: _____

After riding your vehicle in water, be sure to drain the trapped water by removing the check hose at the bottom of the air filter case, the V-belt cooling duct check hose, the drive select lever box check hose and the V-belt case drain plug. Wash the vehicle in fresh water if it has been operated in salt water or muddy conditions.

Vehicle Immersion

CAUTION: _____

If your vehicle becomes immersed, major engine damage can result if the machine is not thoroughly inspected. Take the vehicle to your service center before starting the engine.

If it is impossible to take your vehicle to a service center before starting it, follow the steps outlined below.

1. Move the vehicle to dry land.
2. Check the air box. If water is present, dry the air box and replace the filter with a new filter.
3. Remove the spark plugs.
4. Turn the engine over several times.

5. Dry the spark plugs and reinstall them, or install new plugs.
6. Attempt to start the engine. If necessary, repeat the drying procedure.
7. Take the vehicle to your service center for service as soon as possible, whether you succeed in starting it or not.
8. If water has been ingested into the CVT, make sure to inspect the hole without water left inside. If it is muddy water, open the CVT cap and wash the parts before you reassemble.
9. Check the gearshift, release the water inside. Wash if necessary.

CAUTION:

Make sure all components that are washed and assembled are coated lightly with grease.

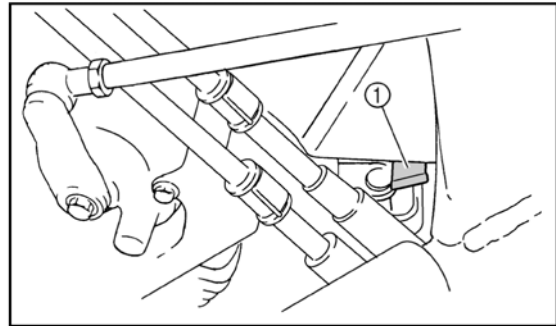

1. Air filter case check hose

7-15 Your Vehicle

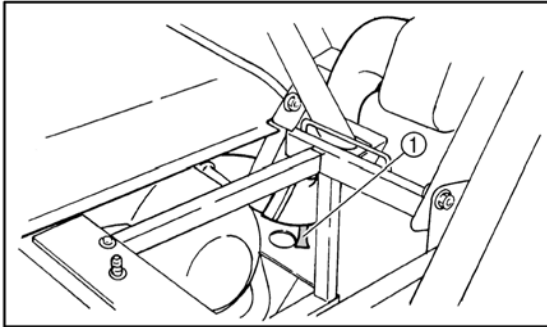

1. V-belt cooling duct check hose

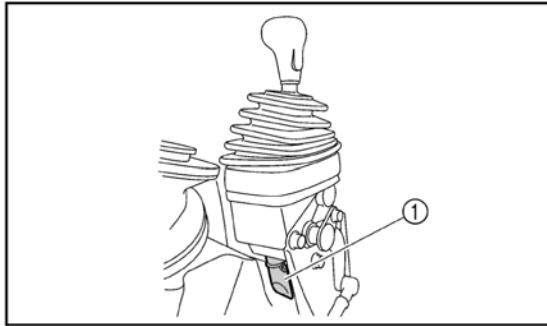

1. Drive select lever box check hose

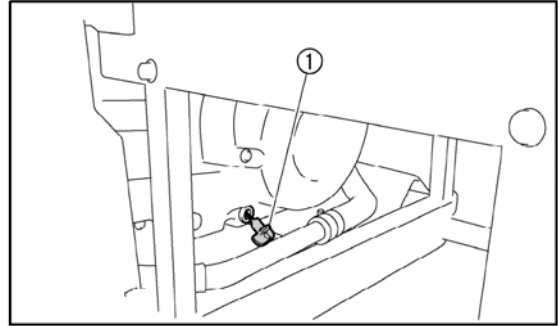

1. V-belt case drain plug

Riding Over Rough Terrain

Operating over rough terrain should be done with caution. Look for obstacles that could cause damage to the vehicle or could lead to a rollover accident. Avoid jumping the vehicle as injury, loss of control, and damage to the

vehicle could occur.

⚠ WARNING

POTENTIAL HAZARD

Failure to use extra care when operating this vehicle on unfamiliar terrain.

WHAT CAN HAPPEN

You can come upon hidden rocks, bumps, or holes, without enough time to react. Could result in the vehicle overturning or going out of control.

HOW TO AVOID THE HAZARD

Go slowly and be extra careful when operating on unfamiliar terrain. Always be alert to changing terrain conditions when operating the vehicle.



7-17 Your Vehicle

Riding in Brush or Wooded Areas

When operating in areas with brush or trees, watch carefully on both sides and above the vehicle for obstacles such as branches that the vehicle might hit, causing an accident, or for brush that might enter the vehicle as you pass and strike the driver or passenger.

Never hold onto the enclosure so your hand is outside the vehicle. Hold the handgrip inside the enclosure.

Encountering Obstacles on the Trail

If you cannot go around an obstacle such as a fallen tree trunk or a ditch, stop the vehicle where it is safe to do so. Set the parking brake and get out to inspect the area

thoroughly. Look from both your approach side and the exit side. If you believe you can continue safely, decide the path that will allow you to get over the obstacle at as close to a right angle as possible to minimize vehicle tipping. Go only fast enough to maintain your momentum but still give yourself plenty of time to react to changes in conditions. If there is any question about your ability to maneuver safely over the obstacle, you should turn around, if the ground is flat and you have the room, or back up until you find a less difficult path.

⚠ WARNING

POTENTIAL HAZARD

Improperly operating over obstacles.

WHAT CAN HAPPEN

Could cause loss of control or a collision.

Could cause the vehicle to overturn.

HOW TO AVOID THE HAZARD

Before operating in a new area, check for obstacles.

Use extreme caution when operating over large obstacles, such as large rocks or fallen trees.

8-1 Periodic Maintenance and Adjustment

Periodic Maintenance and Adjustment

Periodic inspection, adjustment and lubrication will keep your vehicle in the safest and most efficient condition possible. Safety is an obligation of the vehicle owner. The most important points of vehicle inspection, adjustment and lubrication are explained on the following pages.

The service information included in this manual is intended to provide you, the owner, with the necessary information for completing your own preventive maintenance and minor repairs. The tools provided in the Owner's tool kit are sufficient for this purpose, except that a torque wrench is also necessary to properly tighten nuts and bolts.

NOTE:

If you do not have a torque wrench available during a service operation requiring one, take your vehicle to service center to check the torque settings and adjust them as necessary.

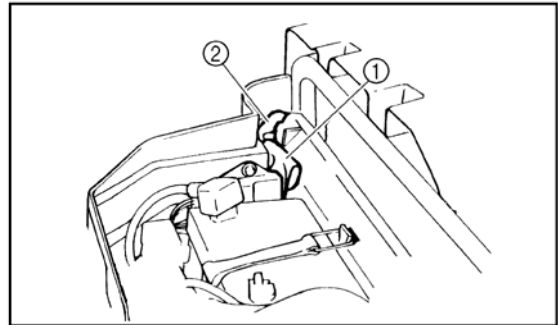

1. Owner's tool kit

2. Tire pressure gauge

⚠ WARNING

POTENTIAL HAZARD

Servicing an engine while it is running.

WHAT CAN HAPPEN

Moving parts can catch clothing or parts of the body, causing injury.
Electrical components can cause shocks or can start fires.

HOW TO AVOID THE HAZARD

Turn off the engine when performing maintenance unless otherwise specified.
Have a service center perform service if you are not familiar with vehicle service.

⚠ WARNING

POTENTIAL HAZARD

Operating this vehicle with improper modifications.

WHAT CAN HAPPEN

Improper installation of accessories or modification of this vehicle may cause changes in handling which in some situations could lead to an accident.

HOW TO AVOID THE HAZARD

Never modify this vehicle through improper installation or use of accessories. All parts and accessories added to this vehicle should be genuine or equivalent components designed for use on this vehicle and should be installed and used according to instructions.

If you have questions, consult an authorized service center.

8-3 Periodic Maintenance and Adjustment

CAUTION:

- Be sure you have sufficient knowledge, experience, the proper replacement parts and tools before you attempt any vehicle maintenance task.
 - If you don't have the knowledge and equipment which are necessary to perform the maintenance task, consult your local dealer.
-

SERVICE INTERVALS

ITEM	MAINTENANCE INTERVAL (WHICHEVER COMES FIRST)			REMARKS
	Hours	Frequency	Miles (KM)	
Pre-Ride Inspection Check				
Steering	-	Pre-Ride	-	Inspect for loose hardware or abnormal wear
Front-suspension	-	Pre-Ride	-	Inspect for loose hardware or abnormal wear
Rear-suspension	-	Pre-Ride	-	Inspect for loose hardware or abnormal wear
Tires	-	Pre-Ride	-	Proper tire pressure
Brake fluid level	-	Pre-Ride	-	Inspect and add if needed
Brake pedal travel	-	Pre-Ride	-	See Owner's Manual

Periodic Maintenance and Adjustment 8-4

ITEM	MAINTENANCE INTERVAL (WHICHEVER COMES FIRST)			REMARKS
	Hours	Frequency	Miles (KM)	
Brake systems	-	Pre-Ride	-	Make adjustments as needed.
Lug Nuts	-	Pre-Ride	-	Ensure lug nuts are torque to spec
Frame fasteners	-	Pre-Ride	-	All fasteners are secured
Engine Oil Level	-	Pre-Ride	-	Inspect and add if needed
Coolant	-	Pre-Ride	-	Inspect and add if needed
Head / Tail / Brake Lights	-	Pre-Ride	-	Check operation
Break-In Maintenance Check				
Engine Oil/Filter change	10	-	First 50 (75)	Replace break-in oil & filter with proper oil type
Transmission	20	-	First 100 (150)	Initial fluid level inspection; add lubricant if needed
Toe adjustment	20	-	First 100 (150)	Inspect periodically; adjust when parts are replaced
Clutches (Drive and Driven)	20	-	First 100 (150)	Inspect; clean; replace worn parts

8-5 Periodic Maintenance and Adjustment

ITEM	MAINTENANCE INTERVAL (WHICHEVER COMES FIRST)			REMARKS
	Hours	Frequency	Miles (KM)	
Routine Maintenance Check (performed at each interval below, whichever comes first)				
Air filter	5 H	-	-	Inspect; replace as needed
Brake pad wear	20 H	Monthly	250 (402)	Inspect periodically
Throttle Body Intake	20 H	1 M	250 (402)	Inspect duct for proper sealing/air leaks
Battery	20H	Monthly	250 (402)	Check terminals; clean; test
Fuel System	25 H	Monthly	250 (402)	Check lines & fittings for leaks
General lubrication	25H	3 M	250 (402)	Lubricate all fittings, pivots, cables, etc.
Shift Linkage	25H	3 M	250 (402)	Inspect, lubricate, adjust
Engine Oil & Filter	50 H	6 M	500 (800)	Replace
Steering	50 H	6 M	500 (800)	Lubricate
Front / Rear Gearcase Fluid	50H	6 M	500 (800)	Change Fluid
Front / Rear Stabilizer Bars	50H	6 M	500 (800)	Lubricate and inspect bushings
Throttle Pedal/Cable	50 H	6 M	500 (800)	Inspect for free movement & lubricate
Drive Belt	50 H	6 M	500 (800)	Inspect; replace as needed

Periodic Maintenance and Adjustment 8-6

ITEM	MAINTENANCE INTERVAL (WHICHEVER COMES FIRST)			REMARKS
	Hours	Frequency	Miles (KM)	
Antifreeze Coolant	50 H	6 M	500 (800)	Pressure Test / Add Fluid
Transmission Fluid	50 H	6 M	500 (800)	Replace
Engine mounts	100 H	12 M	1000 (1600)	Inspect; replace as needed
Cooling Hoses	100 H	12 M	1000 (1600)	Inspect for cracks and leaks
Drive Shafts	100H	12M	1000 (1600)	Remove and grease
Spark plug	100 H	12 M	1000 (1600)	inspect; replace as needed
Clutches (Drive and Driven)	100 H	12 M	1000 (1600)	Inspect; clean; replace worn parts
Wiring	100 H	12 M	1000 (1600)	Inspect for wear & routing
Wheel Bearings	100 H	12 M	1000 (1600)	Inspect; replace as needed
Shocks	100 H	12 M	1000 (1600)	Check for oil leaks
Cam Chain Tensioner	100H	12 M	1000 (1600)	Check; replace as needed
Brake Fluid	100 H	12M	1000 (1600)	Change every two years
Suspension Components	100H	12M	1000 (1600)	Inspect; replace if necessary
Spark arrestor	100H	12 M	-	Clean out

8-7 Periodic Maintenance and Adjustment

ITEM	MAINTENANCE INTERVAL (WHICHEVER COMES FIRST)			REMARKS
	Hours	Frequency	Miles (KM)	
Valve clearance	100 H	12M	1000 (1600)	Inspect; adjust
Extreme Maintenance Check (cut the Routine Maintenance Schedule in half)				
* Service Note: Under extreme use, change gear case fluid every 25 hours. " <i>Extreme Use</i> " is defined as constant <u>4WD</u> operation on hilly or mountainous terrain, or if 4WD is the primary mode of operation.				

LUBRICATION RECOMMENDATIONS

Check and lubricate all components at the intervals outlined in the Periodic Maintenance Chart above, or more often under severe use, such as wet or dusty conditions. Items not listed in the chart should be lubricated at the general lubrication interval.

ITEM	LUBE	METHOD
Engine Oil	See Viscosity Chart (10-2)	Add to proper level on dipstick.
Brake Fluid	DOT 3 or 4 Brake Fluid	Maintain level between fill lines.
Rear Differential	SAE 80w90	Fill to bottom of fill plug or 0.455L or 14 oz.)
Front Differential	Dextron 3 ATF	Fill to bottom of fill plug or (volume of oil)
Drive Shaft	U-Joint Grease	Locate fittings and grease.

ENGINE OIL

Always check and change the oil at the intervals outlined in the Service Interval Chart above. Always use the recommended engine oil. Always change the oil filter whenever changing oil.

Vehicle operation with insufficient, deteriorated, or contaminated engine oil will cause accelerated wear and may result in engine seizure, accident and injury.

Always perform the maintenance procedures as outlined in the Periodic Maintenance Chart. Failure to perform routine maintenance could result in voiding of remaining warranty.

8-9 Periodic Maintenance and Adjustment

Hood

To open

Unhook the hood latches, and then slowly tilt the hood up until it stops.

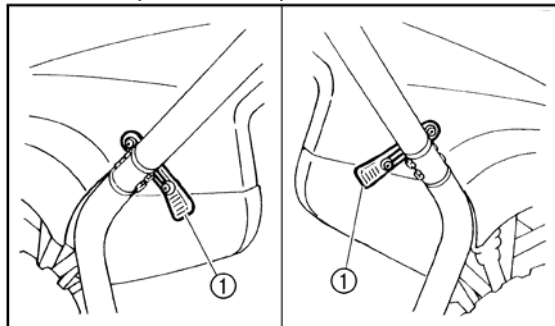

1. Latch (x2)

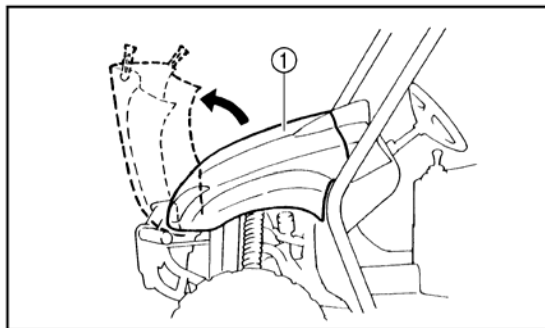

1. Hood

To close

Lower the hood slowly to its original position, and then hook the hood latches.

Secure projections ① on the underside of the hood into slots ② on the back of the instrument panel. Secure slots ③ on the side of the hood around projections ④ on the frame.

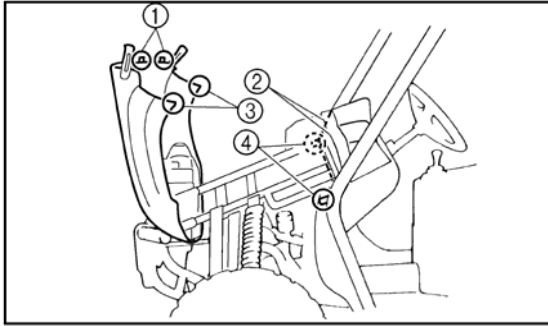

- | | |
|--------------------|--------------------|
| 1. Projection (x2) | 2. Slot (x2) |
| 3. Slot (x2) | 4. Projection (x2) |

CAUTION:

- Make sure that all cables and wires are in place when closing the hood.
- Do not drive the vehicle with the hood open, unlatched, or removed.

Console

To remove

1. Remove the seats. (See pages 4-17—4-18 for seat removal and installation procedures.)
2. Remove the parking brake lever boot.
3. Pull the console upward (the drive select lever boot will come loose.)

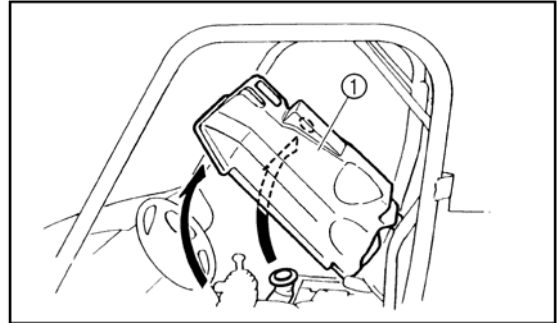

1. Console

8-11 Periodic Maintenance and Adjustment

To install

1. Place the console in its original position.
2. Install the parking brake lever boot.
3. Install the seats.

CAUTION:

- When installing the console, be sure not to pinch the cables or wires.
 - Make sure that the groove at the bottom of the parking brake lever boot and the drive select lever boot fits securely around the edge of the hole in the console.
-

Engine oil and oil filter cartridge

The engine oil level should be checked before each operation. In addition, the oil must be changed and the oil filter cartridge replaced at the intervals specified in the periodic maintenance and lubrication chart.

To check the engine oil level

1. Place the vehicle on a level surface.

2. Remove the console. (See page 8-9 for console removal and installation procedures.)
3. Check the engine oil level on a cold engine.

NOTE:

If the engine was started before checking the oil level, be sure to warm up the engine sufficiently, and then wait at least ten minutes until the oil settles for an accurate reading.

4. Remove the engine oil filler cap and wipe off the dipstick with a clean rag.
5. Insert the dipstick in the oil filler hole (without screwing it in), and then remove it again to check the oil level.

NOTE:

The engine oil should be between the minimum and maximum level marks.

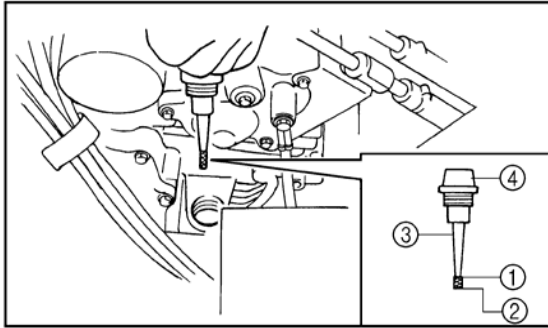

- 1. Maximum level mark
- 2. Minimum level mark
- 3. Dipstick
- 4. Engine oil filler cap

- 6. If the engine oil is at or below the minimum level mark, add sufficient oil of the recommended type to raise it to the correct level.
- 7. Insert the dipstick into the oil filler hole, and then tighten the oil filler cap.

- 8. Install the console.

To change the engine oil (with or without oil filter cartridge replacement)

- 1. Remove the console. (See page 8-9 for console removal and installation procedures.)
- 2. Place an oil pan under the engine to collect the used oil, and then remove the engine oil filler cap.
- 3. Remove the engine oil drain bolt to drain the oil from the crankcase.

8-13 Periodic Maintenance and Adjustment

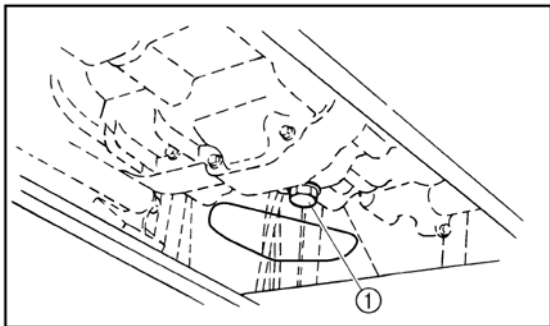

1. Engine oil drain bolt

NOTE: _____

Skip steps 4-6 if the oil filter cartridge is not being replaced.

4. Remove the oil filter cartridge with an oil filter wrench.

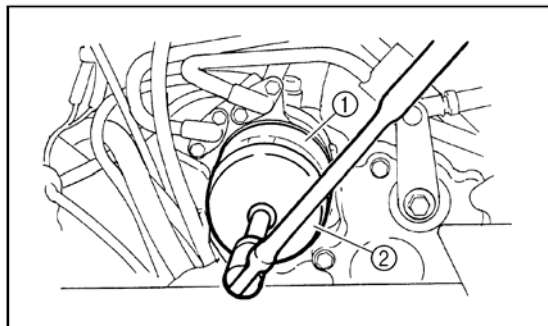

1. Oil filter cartridge
2. Oil filter wrench

NOTE: _____

An oil filter wrench is available at a nearby service center.

5. Apply a light coat of engine oil to the O-ring of the new oil filter cartridge.

NOTE: _____

Make sure the O-ring is seated properly.

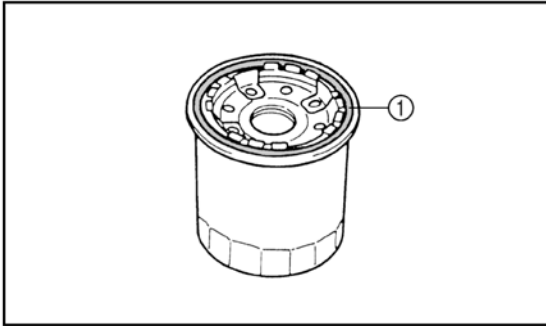

1. O-ring
6. Install the new oil filter cartridge with an oil filter wrench, and then tighten it to the specified torque with a torque wrench.

Tightening torque:
Oil filter cartridge:
12 ft·lbf (17Nm, 1.7m·kgf)

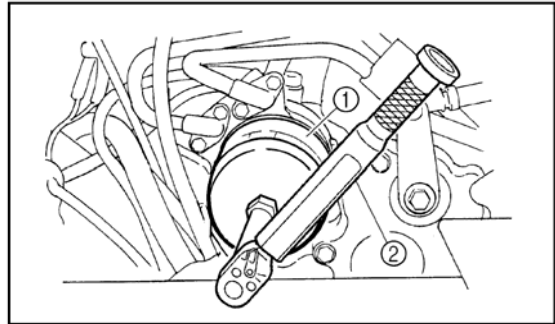

1. Oil filter cartridge
2. Torque wrench
7. Install the engine oil drain bolt, and then tighten it to the specified torque.

Tightening torque:
Engine oil drain bolt:
22 ft·lbf (30Nm, 3.0m·kgf)

8. Add the specified amount of recommended engine oil, and then install engine oil filler cap and tighten.

8-15 Periodic Maintenance and Adjustment

Recommended engine oil:

See page 10-2.

Oil quantity:

Without oil filter cartridge replacement

2.01 qt (1.9L)

With oil filter cartridge replacement:

2.22 qt (2.1L)

CAUTION:

- In order to prevent clutch slippage (since the engine oil also lubricates the clutch), do not mix any chemical additives. Do not use oils with a diesel specification of “CD” or oils of a higher quality than specified. In addition, do not use oils labeled “ENERGY CONSERVING II” or higher.
 - Make sure that no foreign material enters the crankcase.
-

9. Start the engine, and then let it idle for

several minutes while checking it for oil leakage. If oil is leaking, immediately turn the engine off and check for the cause.

10. Turn the engine off, wait at least ten minutes, and then check the oil level and correct it if necessary.
11. Install the console.

Final gear oil

Checking the final gear oil level

1. Place the vehicle on a level surface.
2. Remove the oil filler bolt, and then check the oil level in the final gear case.

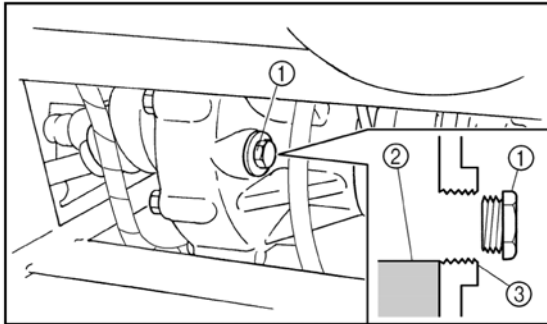

1. Speedometer sensor 2. final gear oil
3. Correct oil level

NOTE:

The oil level should be at the brim of the filler hole.

3. If the oil is below the brim of the filler hole, add sufficient oil of the recommended type to raise it to the correct level.

CAUTION:

1. Be sure no foreign material enters the final gear case.
2. Please clean the sensor every 320 mile period.
3. Install the oil filler bolt, and then tighten it to the specified torque.

Tightening torque:

Final gear oil filler bolt:

17 ft·lbf (23 Nm, 2.3 m·kgf,)

8-17 Periodic Maintenance and Adjustment

Changing the final gear oil

1. Place the vehicle on a level surface.
2. Place a container under the final gear case to collect the used oil.
3. Remove the oil filler bolt and the drain bolt to drain the oil.

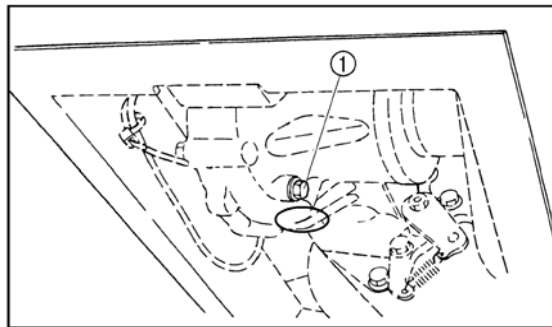

1. Final gear oil drain bolt
4. Install the drain bolt, and then tighten it to the specified torque.

Tightening torque:

Final gear oil drain bolt:
14 ft·lbf (20 Nm, 2.0 m·kgf)

5. Add the recommended final gear oil up to the brim of the filler hole.

Recommended oil:

SAE 80 API GL-4Hypoid gear oil

Oil quantity:

0.26 qt (0.25 L)

CAUTION:

Be sure no foreign material enters the final gear case.

6. Install the oil filler bolt, and then tighten it to the specified torque.

Tightening torque:

Final gear oil filler bolt:

17 ft·lbf (23 Nm, 2.3 m·kgf)

7. Check for oil leakage. If oil leakage is found, check for the cause.

Differential gear oil

Checking the differential gear oil level

1. Place the vehicle on a level surface.
2. Remove the differential gear oil filler bolt and check the oil level. It should be up to the brim of the filler hole. If the level is low, add sufficient oil of the recommended type to raise it to the specified level.

CAUTION:

Be sure no foreign material enters the differential gear case.

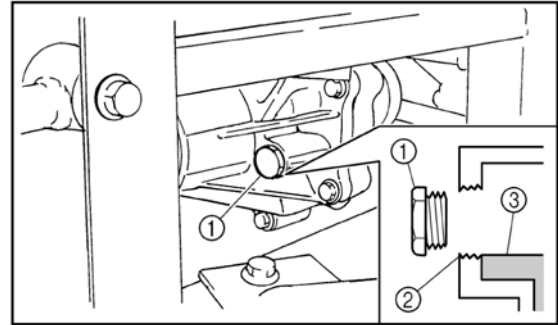

1. Differential gear oil filler bolt

2. Correct oil level

3. Differential gear oil

3. Install the differential gear oil filler bolt, and then tighten it to the specified torque.

Tightening torque:

Differential gear oil filler bolt:

17 ft·lbf (23Nm, 2.3 m·kgf)

8-19 Periodic Maintenance and Adjustment

Changing the differential gear oil

1. Place the vehicle on a level surface.
2. Place a container under the differential gear case to collect the used oil.
3. Remove the differential gear oil filler bolt and differential gear oil drain bolt to drain the oil.

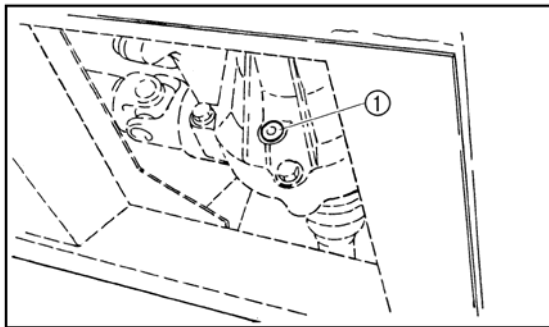

1. Differential gear oil drain bolt
4. Install the differential gear oil drain bolt, and tighten it to the specified torque.

Tightening torque:

Differential gear oil drain bolt:

7.1 ft·lbf (9.8Nm, 0.98 m·kgf)

5. Fill the differential gear case with the recommended oil.

Recommended oil:

SAE 80 API GL-5 Hypoid gear oil

Oil quantity:

0.34 qt (0.32 L)

CAUTION:

Be sure no foreign material enters the differential gear case.

6. Install the differential gear oil filler bolt, and then tighten it to the specified torque.

Tightening torque:

Differential gear oil filler bolt:
17 ft·lbf (23Nm, 2.3m·kgf)

7. Check for oil leakage. If oil leakage is found, check for the cause.

Coolant

The coolant level should be checked before each ride.

Checking the coolant level

1. Place the vehicle on a level surface.
2. Open the hood. (See pages 8-8—8-9 for hood opening and closing procedures.)
3. Check the coolant level in the coolant reservoir when the engine is cold as the coolant level varies with engine temperature.

NOTE:

The coolant should be between the minimum and maximum level marks.

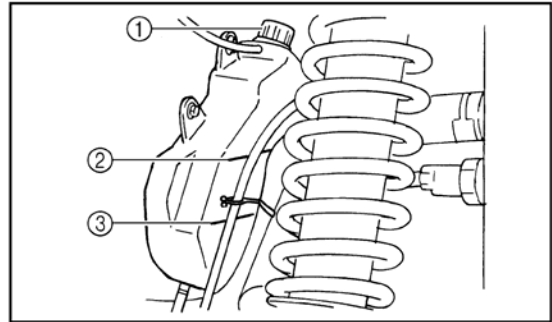

1. Coolant reservoir cap
2. Maximum level mark
3. Minimum level mark
4. If the coolant is at or below the minimum level mark, remove the reservoir cap, add coolant to the maximum level mark, install the reservoir cap, and then close the hood.

8-21 Periodic Maintenance and Adjustment

Coolant reservoir capacity (up to the maximum level mark): 0.37 qt (0.35L)
--

CAUTION:

Mix anti freeze with distilled water only. However, if distilled water is not available, soft water may be used for refilling.

Changing the coolant

The coolant must be changed by a service center at the intervals specified in the periodic maintenance and lubrication chart.

NOTE:

- Adding water instead of coolant lowers the antifreeze content of the coolant. If water is used instead of coolant, have a service center check the antifreeze content of the coolant as soon as

possible.

- The radiator fan is automatically switched on or off according to the coolant temperature in the radiator.
-

Axle boots

Check the protective boots for holes or tears. If any damage is found, have them replaced by a service center.

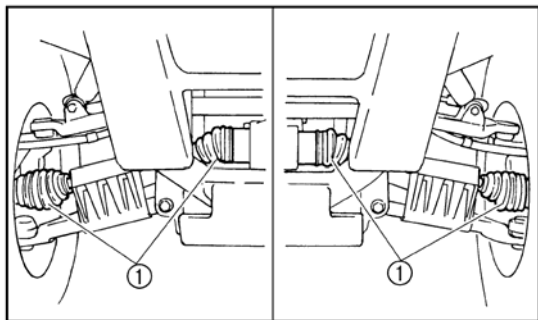

1. Front axle boot (×2 each side)

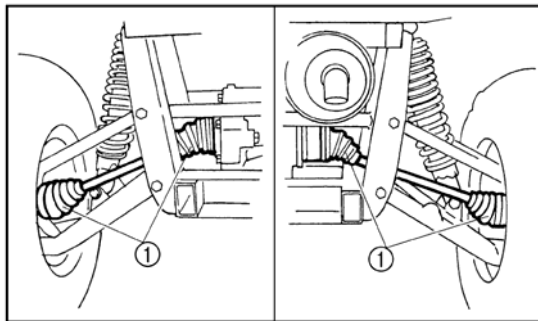

1. Rear axle boot (×2 each side)

Spark plug inspection

Removal

1. Lift the cargo bed up. (See pages 4-21 - 4-22 for cargo bed lifting and lowering procedures.)
2. Remove the spark plug cap.

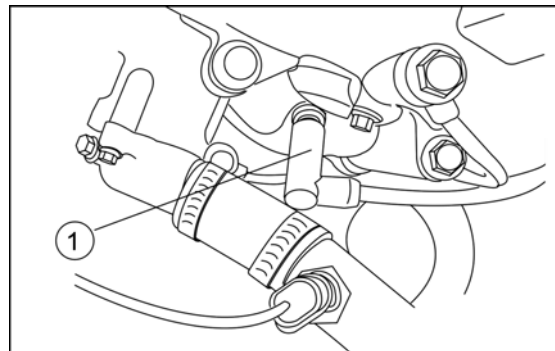

1. Spark plug cap
3. Use the spark plug wrench in the tool kit to remove the spark plug as shown.

8-23 Periodic Maintenance and Adjustment

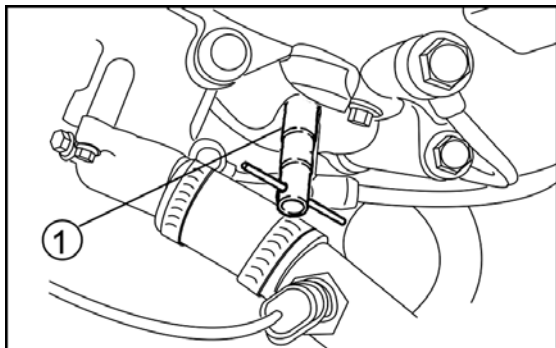

1. Spark plug wrench

Inspection

The spark plug is an important engine component and is easy to inspect. The condition of the spark plug can indicate the condition of the engine. The ideal color of the porcelain insulator around the center electrode is a medium-to-light tan for a vehicle that is being ridden normally.

Do not attempt to diagnose such problems yourself. Instead, take the vehicle to a service center. You should periodically remove and inspect the spark plug because heat and deposits will cause the spark plug to slowly break down and erode. If electrode erosion becomes excessive, or if carbon and other deposits are excessive, you should replace the spark plug with the specified plug.

Specified spark plug:
DR8EA (NGK) for 500
DCPR7E (NGK) for 700

Installation

1. Measure the electrode gap with a wire thickness gauge and, if necessary, adjust the gap to specification.

Spark plug gap:
0.023-0.027 in (0.6 - 0.7 mm)

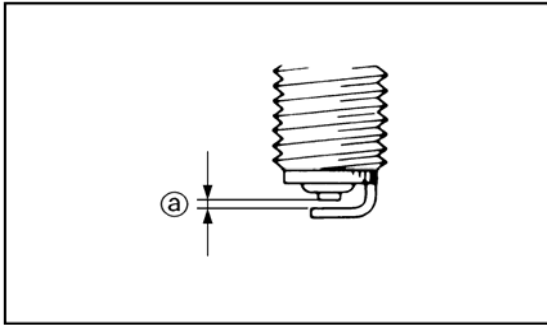

a. Spark plug gap

2. Clean the surface of the spark plug gasket and its mating surface, and then wipe off any grime from the spark plug threads.
3. Install the spark plug and tighten it to the specified torque.

Tightening torque:

Spark plug:

12.7 ft·lbf (17.5 Nm, 1.75 m·kgf)

NOTE:

If a torque wrench is not available when you are installing the spark plug, a good estimate of the correct torque is 1/4 to 1/2 turn past finger tight. Have the spark plug tightened to the specified torque as soon as possible.

4. Install the spark plug cap.
5. Lower the cargo bed.

Cleaning the engine air filter element

NOTE:

There is a check hose at the bottom of the air filter case. If dust or water collects in this hose, empty the hose and clean the air filter element and air filter case.

8-25 Periodic Maintenance and Adjustment

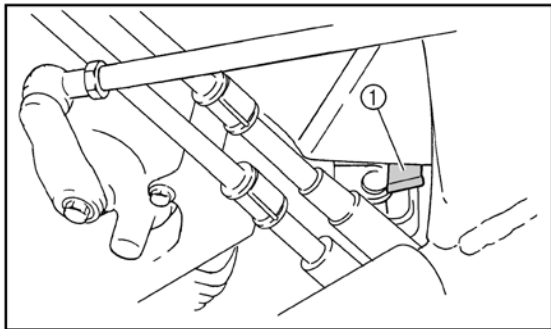

1. Air filter check hose
1. Remove the seats. (See pages 4-17 - 4-18 for seat removal and installation procedures.)
2. Remove the console. (See page 8-9 for console removal and installation procedures.)
3. Remove the air filter case cover by unhooking the holders.

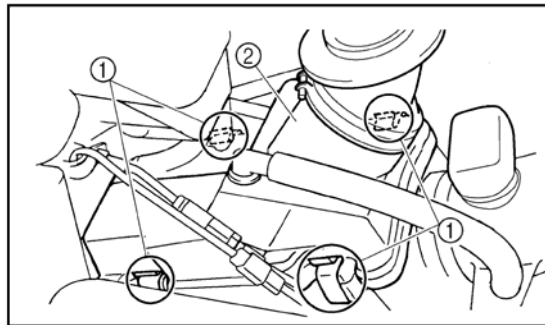

1. Holder (×4)
2. Air filter case cover
4. Remove the air filter element.
5. Remove the sponge material from its frame.

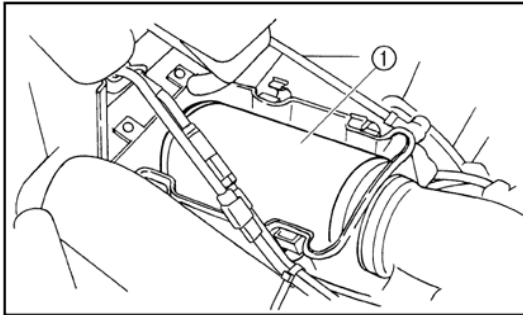

1. Air filter element

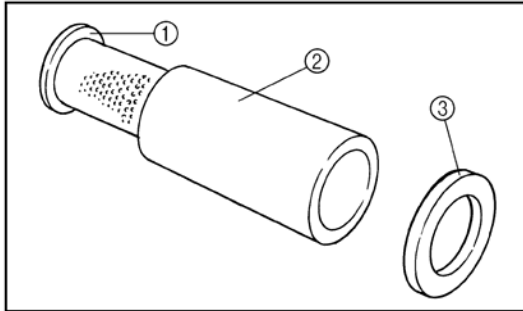

1. Air filter frame
2. Sponge material
3. Element retaining plate

6. Wash the sponge material gently but thoroughly in solvent.

⚠ WARNING

POTENTIAL HAZARD

Using low flash point solvents or gasoline to clean the sponge material.

WHAT CAN HAPPEN

Low flash point solvents or gasoline can catch fire or explode.

HOW TO AVOID THE HAZARD

Use parts cleaning solvent to clean the sponge material.

7. Squeeze the excess solvent out of the sponge material and let it dry.

8-27 Periodic Maintenance and Adjustment

CAUTION: _____

Do not twist the sponge material when squeezing it.

8. Inspect the sponge material and replace it if damaged.
9. Thoroughly apply foam air filter oil or other quality liquid foam air filter oil (not spray type) to the sponge material.

NOTE: _____

The sponge material should be wet but not dripping.

10. Pull the sponge material over its frame.
11. Install the air filter element.
12. Install the air filter case cover and be sure the crankcase breather hose is connected.

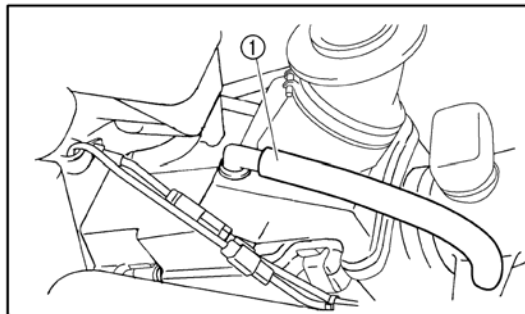

1. Crankcase breather hose

13. Install the console.
14. Install the seats.

NOTE: _____

The air filter element should be cleaned every 20-40 hours. It should be cleaned and lubricated more often if the vehicle is operated in extremely dusty areas. Each time air filter element maintenance is performed,

check the air inlet to the air filter case for obstructions. Check the air filter element rubber joint to the fuel system and manifold fittings securely to avoid the possibility of unfiltered air entering the engine.

CAUTION: _____

Never operate the engine with the air filter element removed. This will allow unfiltered air to enter, causing rapid engine wear and possible engine damage. Additionally, operation without the air filter element will affect performance with subsequent poor performance and possible engine overheating.

Check fuel line and fuel filter

CAUTION: _____

Be sure to stop the engine and remove the key. Check the fuel lines periodically. The fuel lines are subject to wear and old fuel may leak onto a running engine which may cause a fire.

The fuel line connections should be checked annually or every 100 service hours whichever comes first. The fuel line is made of rubber and wears regardless of service period.

1. Park the vehicle on a flat surface and raise the cargo bed.
2. If the fuel line and clamps are damaged or deteriorated, replace them.
3. Check fuel filter if it is clogged by debris or contaminated with water replace it.

8-29 Periodic Maintenance and Adjustment

IMPORTANT

When the fuel line is disconnected for maintenance or repair, close both ends of the fuel line with a piece of clean cloth or paper to prevent dust and dirt from entering. Particular care must be taken not to allow dust and dirt into the fuel pump entrance. Even a small amount of dust or dirt cause premature wear and the malfunction of the fuel pump and injector components.

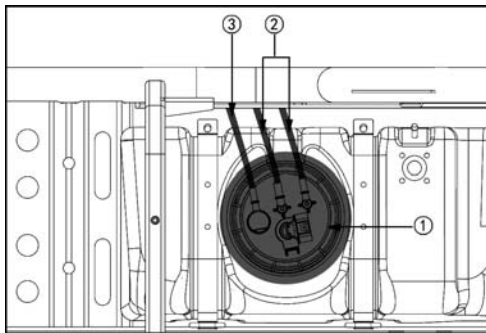

- ① fuel pump
- ② fuel line
- ③ Exit pipe

4. To remove the in-line fuel filter clamps (b), slide the clamps (b) away from the in-line fuel filter (a). Twist and pull the fuel lines off of the in-line fuel filter (a).

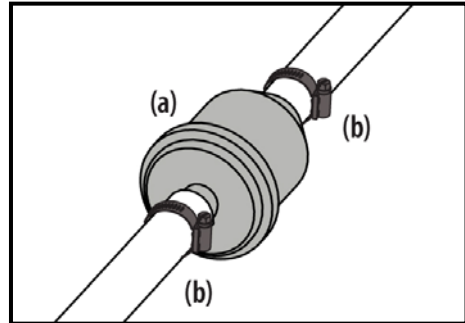

5. Check the in-line filter (a) for debris and/or water contamination. Replace as necessary.

Cleaning the spark arrester

Be sure the exhaust pipe and muffler are cool before cleaning the spark arrester.

1. Remove the bolts.

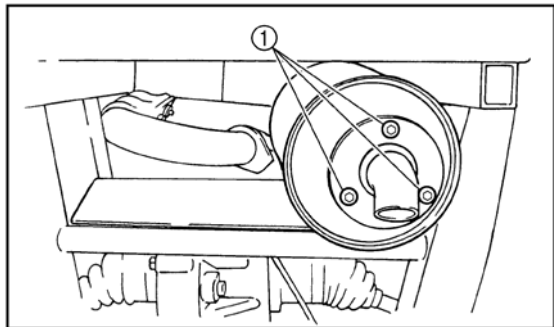

1. Bolt(×3)

2. Remove the tailpipe by pulling it out of the muffler.
3. Tap the tailpipe lightly, and then use a wire brush to remove any carbon deposits from the spark arrester portion

of the tailpipe and inside of the tailpipe housing.

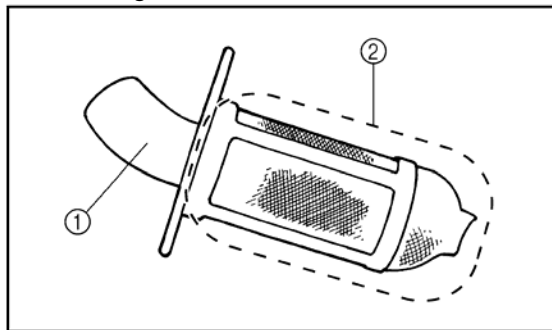

1. Tailpipe

2. Spark arrester

4. Insert the tailpipe into the muffler and align the bolt holes.
5. Install the tailpipe by installing the bolts, and then tighten the bolts to the specified torque.

8-31 Periodic Maintenance and Adjustment

Tightening torque:

Tailpipe bolt:

6.9 ft·lbf (9.5 Nm, 0.95 m·kgf)

WARNING

POTENTIAL HAZARD

Improper cleaning of the spark arrester.

Hot exhaust system

WHAT CAN HAPPEN

Could injure the eyes.

Could cause burns.

Could cause carbon monoxide poisoning, possibly leading to death.

Could start a fire.

HOW TO AVOID THE HAZARD

When cleaning the spark arrester:

Always let the exhaust system cool prior to touching exhaust components.

Do not start the engine when cleaning the exhaust system.

Valve clearance

The correct valve clearance changes with use, resulting in improper fuel-air supply or engine noise. To prevent this, the valve clearance must be adjusted regularly. This adjustment however, should be left to a professional service technician.

Front brake pad check

Each brake pad is provided with wear indicator grooves, which allow you to check the brake pad wear without having to disassemble the brake. To check the brake pad wear, check the wear indicator grooves. If a brake pad has worn to the point that the wear indicator grooves have almost disappeared, have a service center replace the brake pads as a set.

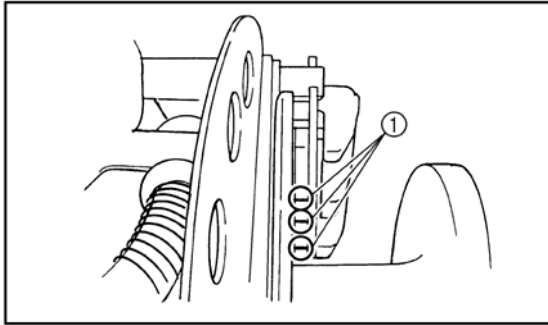

1. Brake pad wear indicator groove

NOTE:

The wheels need to be removed to check the brake pads. (See pages 8-38-8-40 for wheel removal and installation procedures.)

Rear brake pad check

Each brake pad is provided with wear indicator grooves, which allow you to check the brake pad wear without having to disassemble the brake. To check the brake pad wear, check the wear indicator grooves. If a brake pad has worn to the point that the wear indicator grooves have almost disappeared, have a service center replace the brake pads as a set.

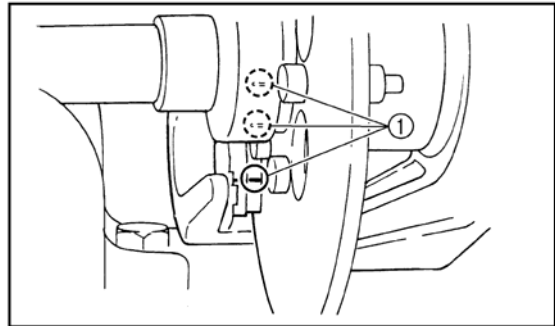

1. Brake pad wear indicator groove

8-33 Periodic Maintenance and Adjustment

Checking the brake fluid level

Insufficient brake fluid may let air enter the brake system, possibly causing the brakes to become ineffective. Before riding, check that the brake fluid is above the minimum level mark and replenish if necessary.

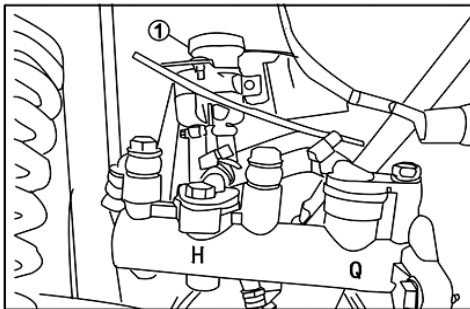

1. Minimum level mark

A low brake fluid level may indicate worn brake pads and/or brake system leakage. If the brake fluid level is low, be sure to check the brake pads for wear and the brake system for leakage.

The brake fluid reservoir is located under the hood. (See pages 8-8- 8-9 for hood opening and closing procedures.)

Observe these precautions:

- When checking the fluid level, make sure the top of the brake fluid reservoir is level.
- Use only the recommended quality brake fluid. Otherwise, the rubber seals may deteriorate, causing leakage and poor braking performance

Recommended brake fluid: DOT 3

- Refill with the same type of brake fluid. Mixing fluids may result a harmful chemical reaction and lead to poor braking performance.
- Be careful that water does not enter the brake fluid reservoir when refilling. Water will significantly lower the boiling point of

the fluid and may result in vapor lock.

- Brake fluid may deteriorate painted surfaces or plastic parts. Always clean up spilled fluid immediately.
- Have a service center inspect the brake system if the brake fluid level goes down.

Brake fluid replacement

Complete fluid replacement should be done only by trained service personnel. Have a service center replace the following components during periodic maintenance or when they are damaged or leaking.

- Replace the oil seals every two years.
- Replace the brake hoses every four years.

Checking the brake pedal

Have a service center check the brakes at the intervals specified in the periodic maintenance and lubrication chart. There

should be no free play in the brake pedal.

The brakes should operate smoothly and there should be no brake drag. If the brakes feel soft or spongy, this could indicate air in the brake system. Have a service center check the brake system if necessary.

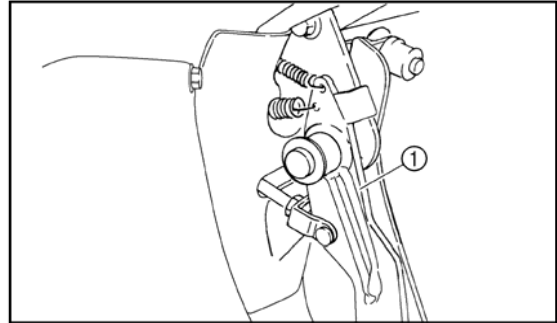

1. Brake pedal

8-35 Periodic Maintenance and Adjustment

WARNING

POTENTIAL HAZARD

Operating with improperly serviced or adjusted brakes.

WHAT CAN HAPPEN

You could lose braking ability, which could lead to an accident.

HOW TO AVOID THE HAZARD

After servicing:

- **Make sure the brakes operate smoothly and that the brake pedal position is correct.**
- **Make sure the brakes do not drag.**
- **All air must be bled from the brake system.**

Replacement of brake components requires professional knowledge. These procedures should be performed by a service center.

Parking brake lever free play adjustment

Periodically check the parking brake lever free play and adjust it if necessary.

1. Shift the drive select lever into low gear “L” .
2. Remove the seats. (See page 4-16 - 4-17 for seat removal and installation procedures.)
3. Remove the console. (See page 8-9 for console removal and installation procedures.)
4. Check the parking brake lever free play. The maximum free play is equal to one click of the parking brake lever. If necessary, adjust the free play as follows.

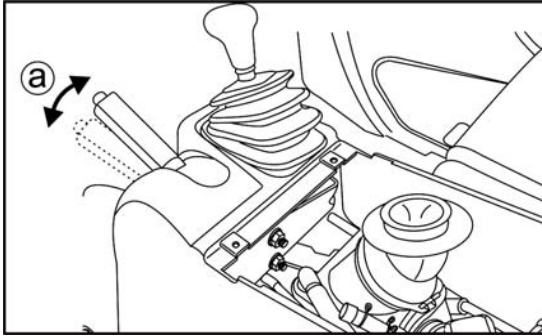

1. Parking brake lever free play

NOTE: _____
The parking brake lever must be released when checking and adjusting the parking brake lever free play.

5. Loosen the locknut.

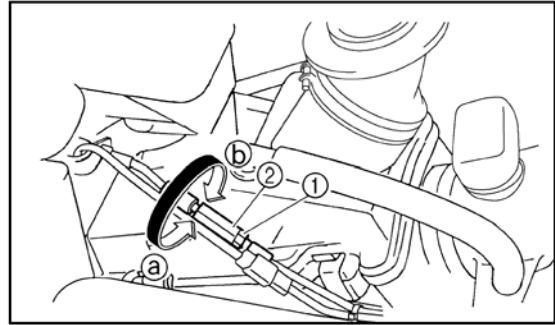

1. Locknut

2. Adjusting nut

6. Turn the adjusting nut in direction **a** to increase the free play or in direction **b** to decrease the free play.
7. Tighten the locknut.
8. Install the console.
9. Install the seats.

8-37 Periodic Maintenance and Adjustment

Brake light switch adjustment

The brake light switch, which is activated by the brake pedal, is properly adjusted when the brake light comes on just before braking takes effect. If necessary, adjust the brake light switch as follows.

1. Open the hood. (See pages 8-8 - 8-9 for hood opening and closing procedures.)
2. Turn the adjusting nut while holding the brake light switch in place. To make the brake light switch in place. To make the brake light come on earlier, turn the adjusting nut in direction **(a)**. To make the brake light come on later, turn the adjusting nut in direction **(b)**.

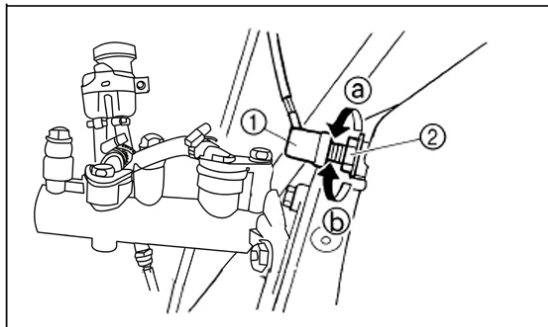

1. Brake light switch.
2. Adjusting nut
3. Close the hood.

Cable inspection and lubrication

Lubricate the inner cables and the cable ends. If the cables do not operate smoothly, ask a service center to replace them.

⚠ WARNING

POTENTIAL HAZARD

Damaged control cables.

WHAT CAN HAPPEN

Corrosion can result when the outer covering of control cables becomes damaged. Cables can also become frayed or kinked. Operation of controls could be restricted, which could cause an accident or injury.

HOW TO AVOID THE HAZARD

Inspect cables frequently. Replace damaged cables.

Recommended lubricant:
Engine oil

Brake pedal and accelerator pedal lubrication

Lubricate the pivoting parts.

Recommended lubricant:

Lithium-soap-based grease
(all-purpose grease)

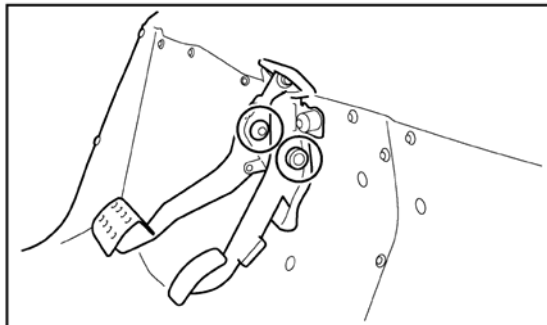

8-39 Periodic Maintenance and Adjustment

Rear knuckle upper and lower pivot lubrication

Lubricate the knuckle upper and lower pivots with a grease gun.

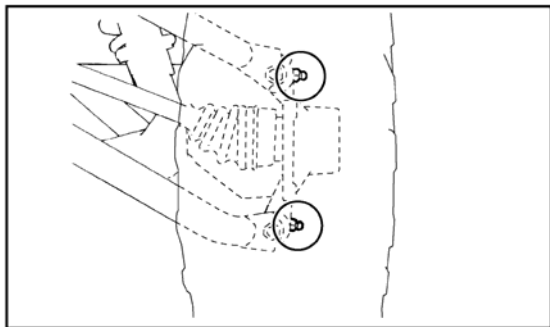

Recommended lubricant:
Lithium-soap-based grease

Steering shaft lubrication

Lubricate the pivot points.

Recommended lubricant:
Lithium-soap-based grease
(all-purpose grease)

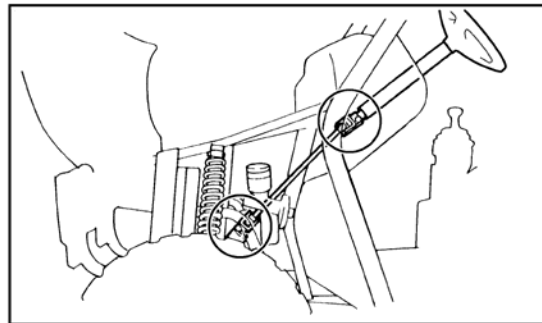

Wheel removal

- Loosen the wheel nuts .
- Elevate the vehicle and place a suitable stand under the frame.
- Remove the nuts from the wheel.
- Remove the wheel.

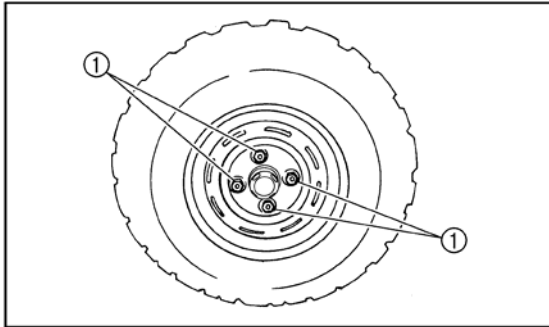

1. Nut (×4)

Wheel installation

- 1. Install the wheel and the nuts.

NOTE:

- The arrow mark ↩ on the tire must point toward the rotating direction of the wheel.
- Tapered nuts are used for both the front and rear wheels. Install the nut with its tapered side towards the wheel.

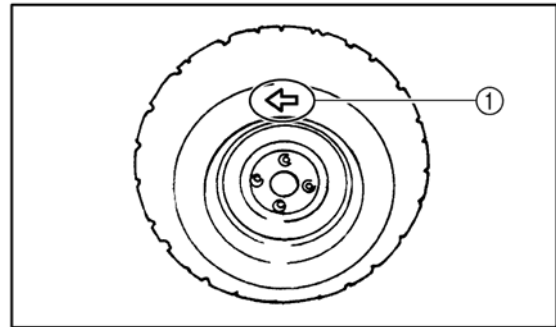

1. Arrow mark

8-41 Periodic Maintenance and Adjustment

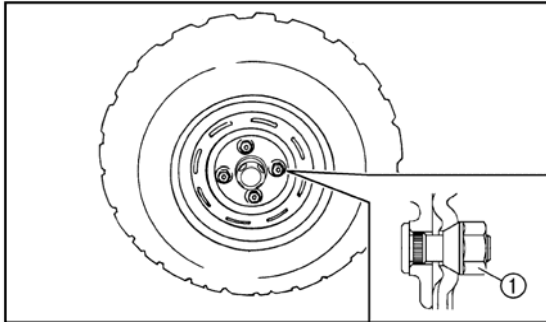

1. Tapered nut
2. Lower the vehicle so that the wheel is on the ground.
3. Tighten the wheel nuts to the specified torque.

Wheel nut torque:

Front: 40 ft·lbf (55Nm, 5.5 m·kgf)

Rear: 40 ft·lbf (55Nm, 5.5 m·kgf)

Battery

This vehicle is equipped with a sealed-type battery. Therefore it is not necessary to check the electrolyte or add distilled water in the battery. If the battery seems to have discharged, consult a service center.

CAUTION:

Do not try to remove the sealing caps of the battery cells. You may damage the battery.

⚠ WARNING

POTENTIAL HAZARD

Failure to handle batteries or battery electrolyte carefully.

WHAT CAN HAPPEN

You could be poisoned. You could be severely burned by the sulfuric acid in battery electrolyte. Batteries produce explosive gases.

HOW TO AVOID THE HAZARD

Avoid contact with skin, eyes or clothing. Always shield eyes when working near batteries. Keep out of reach of children.

Antidote:

EXTERNAL: Flush with water.

INTERNAL: Drink large quantities of water or milk. Follow with milk of magnesia, beaten egg or vegetable oil. Get prompt medical attention.

EYES: Flush with water for 15 minutes and get prompt medical attention. Keep batteries away from sparks, flames, cigarettes or other sources of ignition. Ventilate when charging or using in a closed space.

8-43 Periodic Maintenance and Adjustment

Battery maintenance

1. When the vehicle is not used for a month or longer, remove the battery and store it in a cool, dark place. Completely recharge the battery before reinstallation.

CAUTION:

A special battery charger (constant voltage/ampere or constant voltage) is required for recharging a sealed-type battery. Using a conventional battery charger may shorten the battery life.

2. Always make sure the connections are correct when putting the battery back in the vehicle.

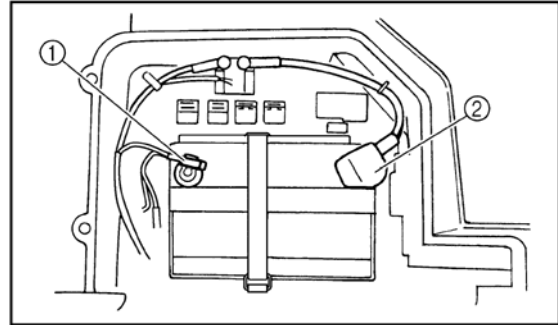

1. Negative battery lead 2. Positive battery lead

Fuse replacement

The main fuse and the fuse box are located under the hood. (See pages 8-8 - 8-9 for hood opening and closing procedures.) If a fuse is blown, turn off the main switch and install a new fuse of the specified amperage.

If a fuse is blown, replace it as follows.

1. Remove the battery compartment cover

by lifting it up and pulling it out.

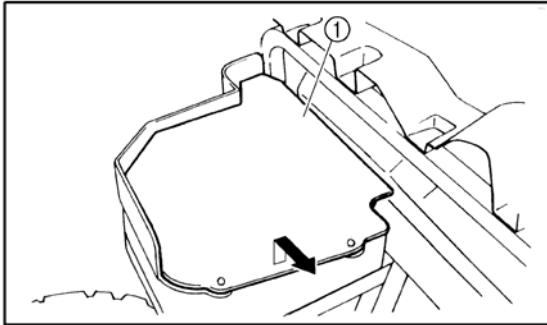

1. Battery compartment cover
2. Turn the key to “OFF” and turn off the electrical circuit in question.

CAUTION:

To prevent accidental short-circuiting, turn off the main switch when checking or replacing a fuse.

3. Remove the blown fuse, and then install a new fuse of the specified amperage.

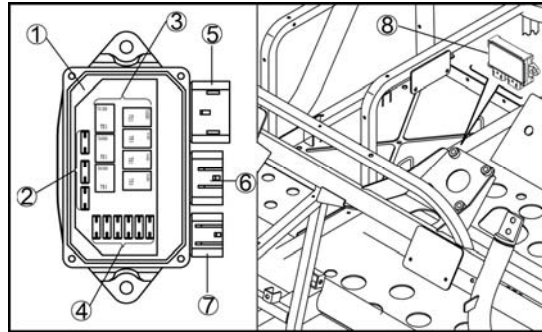

1. Relay assembly
2. Backup fuse
3. Relay
4. Fuse box
5. Adapter connector 3
6. Adapter connector 2
7. Adapter connector 1
8. ECU

8-45 Periodic Maintenance and Adjustment

Specified Fuse:

Main Fuse:	30.0A
Headlight Fuse:	15.0A
ECU、Pump Fuse:	15.0A
Auxiliary DC Jack Fuse:	15.0A
Signaling System Fuse:	10.0A
2WD/4WD、EPS Fuse:	10.0A
Backup Fuse:	5.0A/10.0A/15.0A
Speed meter/ECU	5.0A
-normal open Fuse:	

4. Turn the key to “ON” and turn on the electrical circuit in question to check if the device operates.
5. If the fuse immediately blows again, have a service center check the electrical system.
6. Install the battery compartment cover.
7. Close the hood.

WARNING

POTENTIAL HAZARD

Using an improper fuse

WHAT CAN HAPPEN

An improper fuse can cause damage to the electrical system, which could lead to a fire.

HOW TO AVOID THE HAZARD

A/ways use a fuse of the specified rating. Never use a material in place of the proper fuse.

Replacing a headlight bulb

If a headlight bulb burns out, replace it as follows.

1. Lift the hood up. (See pages 8-8-8-9 for hood opening and closing procedures.)
2. Remove the cover at the rear of the headlight by pulling it off.

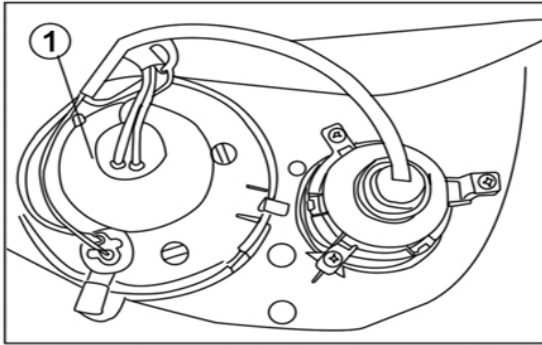

1. Cover at the rear of the headlight

3. Remove the headlight bulb holder cover by pulling it off.

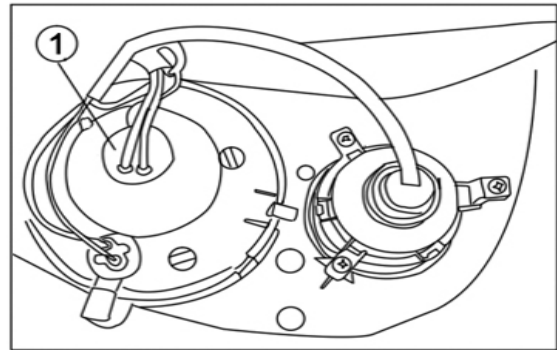

1. Headlight bulb holder cover

4. Remove the headlight bulb holder by pushing it in and turning it counterclockwise.

8-47 Periodic Maintenance and Adjustment

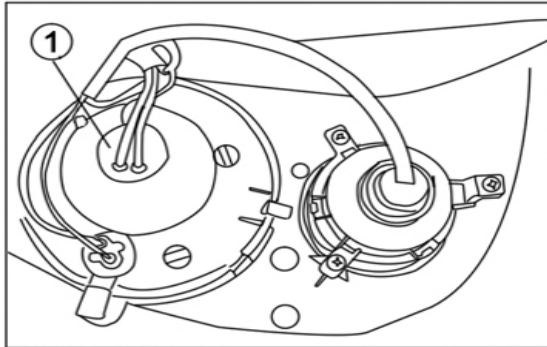

1. Headlight bulb holder

5. Remove the defective bulb by pulling it out.

⚠ WARNING

POTENTIAL HAZARD

A headlight bulb is hot when it is on and immediately after it is turned off.

WHAT CAN HAPPEN

You can be burned, or a fire could start if the bulb touches something flammable.

HOW TO AVOID THE HAZARD

Wait for the bulb to cool before touching or removing it.

6. Insert a new headlight bulb into the bulb holder by pushing it in.

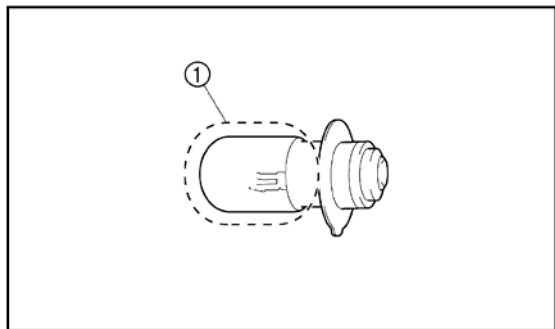

1. Do not touch the glass part of the bulb.

CAUTION: _____
Do not touch the glass part of the headlight bulb to keep it free from oil, otherwise the transparency of the glass, the luminosity of the bulb, and the bulb life will be adversely affected. Thoroughly clean off any dirt and fingerprints on the headlight bulb using a cloth moistened with alcohol or thinner.

7. Install the bulb holder by pushing it is and

turning it clockwise.

8. Install the bulb holder cover and the cover at the rear of the headlight.

CAUTION: _____
Make sure the headlight bulb holder cover is securely fitted over the bulb holder and seated properly.

9. Close the hood.

10. Adjust the headlight beam if necessary.

Headlight beam adjustment

CAUTION: _____
It is advisable to have a service center make this adjustment.

To raise the beam, turn the adjusting screw in direction **a**.

To lower the beam, turn the adjusting screw in direction **b**.

8-49 Periodic Maintenance and Adjustment

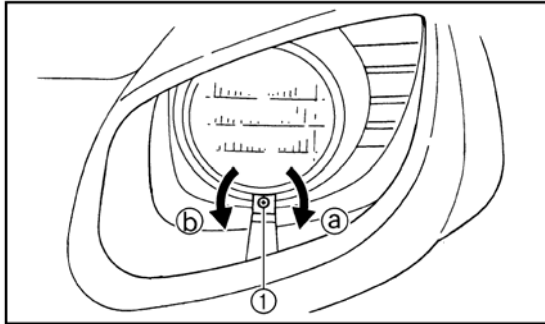

1. Headlight beam adjusting screw

Tail/brake light bulb replacement

If a tail/brake light bulb burns out, replace it as follows:

1. Remove panel A (if replacing the left tail/brake bulb) or panel B (if replacing the right tail/brake bulb) by removing the quick fasteners and bolts.

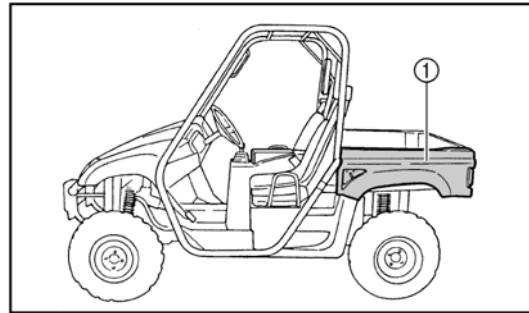

1. Panel A

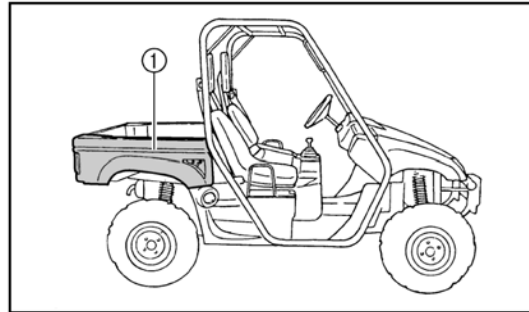

1. Panel B

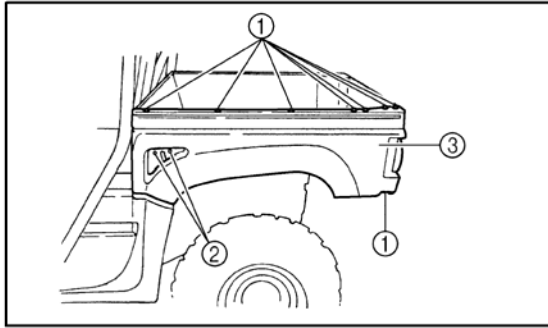

1. Quick fastener (×8)
 2. Bolt (×2)
 3. Panel A
2. Remove the bulb holder (together with the bulb) by turning it counterclockwise.

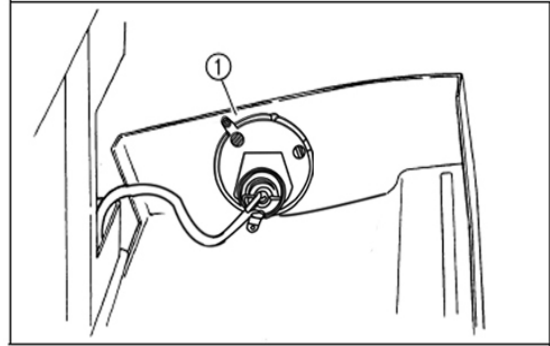

1. Tail/brake light bulb holder
3. Push the defective bulb in and turn it counterclockwise to remove it from the bulb holder.
4. Push a new bulb in and turn it clockwise to install in the bulb holder.
5. Install the bulb holder (together with the bulb) by turning it clockwise.
6. Install the panel by installing the quick fasteners and bolts, and then tighten the bolts to the specified torque.

8-51 Periodic Maintenance and Adjustment

Tightening torque:

Panel bolt:

4.7 ft·lbf (6.5N·m, 0.65 m·kgf)

Troubleshooting

Although vehicles receive a rigid inspection before shipment from the factory, trouble may occur during operation. Any problem in the fuel, compression, or ignition systems can cause poor starting and loss of power. The troubleshooting chart describes a quick, easy procedure for making checks. If your vehicle requires any repair, take it to a service center.

The skilled technicians at a service center ship have the tools, experience, and know how to properly service your vehicle.

Imitation parts may look like genuine parts, but they are often inferior.

Consequently, they have a shorter service life and can lead to expensive repair bills.

WARNING

POTENTIAL HAZARD

Checking the fuel system while smoking or near an open flame.

WHAT CAN HAPPEN

Fuel can ignite or explode, causing severe injury or property damage.

HOW TO AVOID THE HAZARD

Do not smoke when checking the fuel system. Make sure there are no open flames or sparks in the area, including pilot lights from water heaters or furnaces.

Solution to Common Problems in Vehicle

The below tables show some common problems that may come up when you are driving a UTV, which will help to solve these problems. To repair a UTV requires technical skills, if you cannot repair the UTV yourself, please contact your service center.

Table 1: Solution of Common Problems in Appearance Parts and Impact Fittings.

S/N	Problems	Solutions
1	Covers are cracked.	1. Repair cover at authorized service center.
		2. Change for new plastic covers.
		3. Replace the stickers and re-rivet the warning labels.
2	Vehicle's bottom protection plate is damaged by ground.	1. Check if the reduction gear box and differential in front and rear bridge are damaged or if there is any oil leakage.
		2. Check if the bottom of engine is damaged or if there is any oil leakage.
		3. Install a new bottom protection plate.

8-53 Periodic Maintenance and Adjustment

Table 2: Solution of Common Problems in Brake System.

S/N	Problems	Solutions
1	Brake system is locked up.	1. Check if the handle of parking brake return to its position.
		2. Check if the brake discs are bent or deformed.
		3. Check if the calipers' hydraulic cylinders are stuck or the fasteners are bent.
2	Brake performance is diminished.	1. Check if the brake discs are over-worn.
		2. Check if the brake blocks in calipers are over-worn, or contaminated by dirt or debris that can reduce friction.
		3. Check if there is any leakage in brake system's oil lines or junctions.
		4. Check if the post rod in brake master cylinder is bent.
		5. Check if there is any air going into the oil lines, and drain the air with special equipment.
		6. Check if the remaining oil in master cylinders of front and rear brake is still above the lowest level.
3	Front or rear brake system makes unusual noise.	1. Check if the brake discs are bent or warped.
		2. Check if the calipers' hydraulic cylinders are stuck or the

		fasteners of calipers are deformed.
4	Vehicle makes odd turn when braked at high speed.	1. Check if left and right brake force deviation of front brake is within specified limit.
		2. Check if the brake force of front brake goes down, which causes the rear wheels to lock up before the front wheels.
		3. Check if spring force deviation of shock absorbers in front left and right suspension are within specified limit.
		4. Check if the damper rubber sleeves connecting front suspension mount and frame are damaged.

8-55 Periodic Maintenance and Adjustment

Table 3: Solution of Common Problems in Electrical System

S/N	Problems	Solutions
1	Lights do not work.	1. Check if the headlight switch functions properly.
		2. Check if the wires are broken.
		3. Check if the lamps or bulbs are broken.
2	Vehicle cannot go into 4 wheel drive mode.	1. Check if the control switch on meter board works well.
		2. Check if the differential lock control magneto plug in rear bridge reduction gear box is broken.
		3. Check if the wire is broken.
3	Rear differential will not work.	1. Check if the control switch on meter board works well.
		2. Check if the differential lock control magneto plug in rear bridge reduction gear box is broken.
		3. Check if the wire is broken.
4	Meter display is not normal.	1. Check if the sensor is broken.
		2. Check if the meter is broken.
		3. Check if the surface of speed sensor is contaminated with iron dust.
5	Start switch on meter board will not work.	1. Check if the switch is broken.
		2. Check if the wire is broken.
		3. Check if the ECU in electrical injection system is broken.

Table 4: Solution of Common Problems in Running System

S/N	Problems	Solutions
1	Swing clearance of steering wheel is out of specification.	1. Check the fasteners connecting steering rod to steering stem and knuckle to find out if they are loose or broken.
		2. Check the bolts on the ends of steering rod to find out if they are broken.
		3. Check the clearance between gears of steering machine if it is too big.
2	Front wheels shake during use.	1. Check the bearings in knuckles if they are broken.
		2. Check the main ball pins to find out if they are broken.
		3. Check the lock screws of front wheels and axles to find out if they are loose or broken.
		4. Check the inner splines of front wheel hubs and outer splines of front wheel axles to find out if they are worn or broken.
		5. Check rubber bushings between the front suspension mounts and frame to find out if they are broken.
3	Rear wheels shake during use.	1. Check the bearing in rear bridge bearing seat to find out if they are broken.
		2. Check the sliding bearing connecting rear bridge and mounts to find out if they are worn or loose.

8-57 Periodic Maintenance and Adjustment

3	Rear wheels shake during use.	3. Check the inner splines of rear wheel hubs and outer splines of rear wheel axles to find out if they are worn or broken.
		4. Check the lock screws of rear wheels and axles to find out if they are loose or broken.
		5. Check rubber bushings between the rear suspension and frame to find out if they are broken.
4	Wheels jump during use.	1. Check if the rims are bent.
		2. Check if the rear wheel axles are bent.
		3. Check if the tires are worn or damaged.
5	Shock absorbers become soft and not comfortable during use.	1. Check if overloaded.
		2. Check if the springs are too soft and need replacing.
		3. Check if the shock absorbers lose their damping force over time.
6	Front bridge makes noise during use.	1. Check if the spline of intermediate driving shaft is broken.
		2. Check if the splines in left & right drive shafts of front & rear bridges are broken.
		3. Check if the gears in rear bridge reduction gear box and differential are over worn.
		4. Check the dust cover of constant velocity universal joint in right & left drive shafts.

Table 5: Solution of Common Problems in Engine System

S/N	Problems	Solutions
1	Idle speed is not stable	1. Check the battery voltage for Within specified value
		2. Check the rectifier output voltage for within specified value
		3. Check MEUI for failure
3	Power performance is falling.	1. Check and clean air filter.
		2. Check muffler for partly block and clean spark arrestor.
		3. Check tire pressure.
4	Popping noise in engine.	1. Check air cleaner and admission line for leak.
		2. Check the connection joint of exhaust pipe with engine or muffler for leak.
		3. Check the grade of gasoline to see if it's too low.
5	Engine is difficult to start at low temperature.	1. Check to determine if the battery voltage drops during cold weather.
		2. If the temperature is under -18°C, have the vehicle placed in warmer place for start.
6	Coolant boils.	1. Check the cooling fan to make sure it is not blocked by dirt or debris.
		2. Check the radiator sensor for damage and check the fan motor for proper operation.
		3. Check if the dilution of the antifreeze and make sure the ratio is 1:1 or greater.

8-59 Periodic Maintenance and Adjustment

		4. Check the coolant drain tube for with air.
7	Engine cannot start.	1. Check the battery charge.
		2. Check the battery connection.
		3. Check the starter for damage.
		4. Check if the ignition loop is in good condition.
		5. Check if the spark plug creating sparks.
		6. Check if the ignition signal is in good condition.
		7. Check if the air cleaner is blocked.
		8. Check to make sure the coolant is not frozen.
		9. Check if the exhaust system is blocked.

 **WARNING**

POTENTIAL HAZARD

Removing the radiator cap when the engine and radiator are still hot.

WHAT CAN HAPPEN

You could be burned by hot fluid and steam blown out under pressure.

HOW TO AVOID THE HAZARD

Wait for the engine to cool before removing the radiator cap. Always use a thick rag over the cap. Allow any remaining pressure to escape before completely removing the cap.

NOTE:

If it is difficult to get the recommended coolant, tap water can be temporarily used, provided that it is changed to the recommended coolant as soon as possible.

9-1 Cleaning and Storage

Cleaning

Frequent, thorough cleaning of your vehicle will not only enhance its appearance but also will improve its general performance and extend the useful life of many components.

1. Before cleaning the vehicle:
 - a. Block off the end of the exhaust pipe to prevent water entry. A plastic bag and strong rubber band may be used.
 - b. Make sure the spark plug and all filler caps are properly installed.
2. If the engine case is excessively greasy, apply degreaser with a paintbrush. Do not apply degreaser to the wheel axles.
3. Rinse the dirt and degreaser off with a garden hose. Use only enough pressure to do the job.

CAUTION:

Excessive water pressure may cause water seepage and deterioration of wheel bearings, brakes, transmission seals and electrical devices. Many expensive repair bills have resulted from improper high-pressure detergent applications such as those available in coin-operated car washes.

4. Once the majority of the dirt is hosed off, wash all surfaces with warm water and mild, detergent-type soap. An old toothbrush or bottlebrush is handy for hard-to-get-at places.
5. Rinse the vehicle off immediately with clean water and dry all surfaces with a

chamois, clean towel or soft absorbent cloth.

6. Clean the seats with vinyl upholstery cleaner to keep the cover pliable and glossy.
7. Automotive type wax may be applied to all painted and chrome plated surfaces. Avoid combination cleaner waxes as many contain abrasives that may scratch the paint or protective finish. When finished, start the engine and let it idle for several minutes.

⚠ WARNING

POTENTIAL HAZARD

Operation with wet brakes after washing.

WHAT CAN HAPPEN

Wet brakes may have reduced stopping ability, increasing the chance of an accident.

HOW TO AVOID THE HAZARD

Test the brakes after washing. Apply the brakes several times at slow speeds to let friction dry out the linings.

9-3 Cleaning and Storage

Storage

Long-term storage (60 days or more) of your vehicle will require some preventive procedures to guard against deterioration.

After thoroughly cleaning the vehicle, prepare for storage as follows:

1. Fill the fuel tank with fresh fuel and add the specified amount of Fuel Stabilizer and Conditioner or equivalent product. Operate the vehicle for at least 5 minutes to distribute treated fuel through the fuel system.
2. Drain the fuel from the fuel system as much as possible and pour the drained fuel into the fuel tank.

Specified amount:

1 oz of stabilizer to each gallon of fuel (or
7.5 ml of stabilizer to each liter of fuel)

NOTE:

Use of fuel stabilizer and conditioner eliminates the need to drain the fuel system. Consult a service center if the fuel system needs to be drained instead.

3. Remove the spark plug, pour about one tablespoon of SAE 10W40 or 20W40 motor oil in the spark plug. Ground the spark plug wire and turn the engine over several times to coat the cylinder wall with oil.
4. Lubricate all control cables.
5. Block up the frame to raise all wheels off the ground.

6. Tie a plastic bag over the exhaust pipe outlet to prevent moisture from entering.
7. If storing in a humid or salty atmosphere, coat all exposed metal surfaces with a light film of oil. Do not apply oil to any rubber parts or the seat covers.
8. Remove the battery and charge. Store it in a dry place and recharge it once a month. Do not store the battery in an excessively warm or cold place (less than 32°F (0°C) or more than 86°F (30°C)).

NOTE:

Make any necessary repairs before storing the vehicle.

10-1 Specifications

Model	500/700cc
Dimensions: Overall length Overall width Overall height Seat height Wheelbase Ground clearance Minimum turning radius	3010mm (118.5 in) 1460mm (57.5 in) 1940mm (76.4 in) 818mm (32.2 in) 1890mm (74.4 in) 280mm (11.0 in) 3900mm (154 in)
Basic weight with oil and full fuel tank	658 kg (1,451 lb)/690 kg (1,521 lb)
Engine: Engine type Cylinder arrangement Displacement Bore x stroke Compression ratio Starting system Lubrication system	Liquid cooled 4-stroke, Water cool Forward-inclined single cylinder 471cm ³ / 686.0cm ³ 84.5x84.0mm / 102x84.0mm 9.4:1/ 9.2:1 Electric starter Wet sump

10-3 Specifications

Model	500/700cc
Quantity: Without oil filter cartridge replacement With oil filter cartridge replacement	1.90L (2.01 qt) 2.10L (2.22 qt)
Final gear case oil: Type Quantity:	SAE80 API GL-4 Hypoid gear oil 0.25L (0.26 qt)
Differential gear case oil: Type Quantity:	SAE80 API GL-5 Hypoid gear oil 0.32L (0.34 qt)
Radiator capacity (including all routes) :	2.50L (2.64 qt)
Air filter: Engine Intake duct	Wet element Dry element
Fuel: Type Fuel tank capacity	Unleaded gasoline only 28 L (7.4 gal)
Throttle valve: Type/quantity	D46-U / 1

10-5 Specifications

Model	500/700cc																
Tire: Type Size <table style="margin-left: 200px; border: none;"> <tr> <td style="padding-right: 20px;">front</td> <td></td> </tr> <tr> <td>rear</td> <td></td> </tr> </table>	front		rear		Tubeless 26×9-14 26×11-14												
front																	
rear																	
Brakes: I : Front brake <table style="margin-left: 100px; border: none;"> <tr> <td>Type</td> <td></td> </tr> <tr> <td>Operation</td> <td></td> </tr> </table> Rear brake <table style="margin-left: 100px; border: none;"> <tr> <td>Type</td> <td></td> </tr> <tr> <td>Operation</td> <td></td> </tr> </table> II : Front brake <table style="margin-left: 100px; border: none;"> <tr> <td>Type</td> <td></td> </tr> <tr> <td>Operation</td> <td></td> </tr> </table> Rear brake <table style="margin-left: 100px; border: none;"> <tr> <td>Type</td> <td></td> </tr> <tr> <td>Operation</td> <td></td> </tr> </table>	Type		Operation		Type		Operation		Type		Operation		Type		Operation		Dual disc brake Foot operation Single disc brake Foot operation Dual disc brake Foot operation Dual disc brake Foot operation
Type																	
Operation																	
Type																	
Operation																	
Type																	
Operation																	
Type																	
Operation																	
Suspension: Front / rear suspension	Double wishbone																

Model	500/700cc
Shock absorber: Front shock absorber Rear shock absorber	Coil spring/oil damper Coil spring/oil damper
Wheel travel: Front wheel travel Rear wheel travel	130mm (5.12in) 150mm (5.91in)
Electrical: Ignition system Generator system Battery type Battery capacity	ECU AC magneto U1L-11 or GSU1-9 12V32.0Ah or 12V30.0Ah
Bulb voltage, wattage × quantity: Headlight Tail/brake light	12V30.3W/30.0W × 2 12V5.0W/21.0W × 2
Indicator lights: Neutral / Reverse indicator light Coolant temperature warning light Parking brake indicator light	LED LED LED

10-7 Specifications

Model	500/700cc
On-Command four-wheel-drive/differential gear lock indicator	LED
On-Command differential gear lock indicator light	LED
High-range/ Low-range indicator light	LED
Specified fuses: Main Fuse: Headlight Fuse: ECU、 Pump Fuse: Auxiliary DC Jack Fuse: Signaling System Fuse: 2WD/4WD、 EPS Fuse:	30.0A 15.0A 15.0A 15.0A 10.0A 10.0A

Fault Code of Electronic Injection System

DTC Number	DTC Description	Related Calibration	HEX	DEC
P0107	MAP Circuit Low Voltage or Open	KsDGDM_MAP_ShortLow	107	263
P0108	MAP Circuit High Voltage	KsDGDM_MAP_ShortHigh	108	264
P0112	IAT Circuit Low Voltage	KsDGDM_IAT_ShortLow	112	274
P0113	IAT Circuit High Voltage or Open	KsDGDM_IAT_ShortHigh	113	275
P0117	Coolant/Oil Temperature Sensor Circuit Low Voltage	KsDGDM_CoolantShortLow	117	279
P0118	Coolant/Oil Temperature Sensor Circuit High Voltage or Open	KsDGDM_CoolantShortHigh	118	280
P0122	TPS Circuit Low Voltage or Open	KsDGDM_TPS_ShortLow	122	290
P0123	TPS Circuit High Voltage	KsDGDM_TPS_ShortHigh	123	291
P0131	O2S 1 Circuit Low Voltage	KsDGDM_O2_1_ShortLow	131	305

11-2 Fault Code of Electronic Injection System

P0132	O2S 1 Circuit High Voltage	KsDGDM_O2_1_ShortHigh	132	306
P0031	O2S Heater Circuit High Voltage	KsDGDM_O2_HeaterShortHigh	31	49
P0032	O2S Heater Circuit Low Voltage	KsDGDM_O2_HeaterShortLow	32	50
P0201	Injector 1 Circuit Malfunction	KsDGDM_INJ_CYL_A_Fault	201	513
P0202	Injector 2 Circuit Malfunction	KsDGDM_INJ_CYL_B_Fault	202	514
P0230	FPR Coil Circuit Low Voltage or Open	KsDGDM_FPP_CircuitShortLow	230	560
P0232	FPR Coil Circuit High Voltage	KsDGDM_FPP_CircuitShortHigh	232	562
P0336	CKP Sensor Noisy Signal	KsDGDM_CrankNoisySignal	336	822
P0337	CKP Sensor No Signal	KsDGDM_CrankNoSignal	337	823
P0351	Cylinder 1 Ignition Coil Malfunction	KsDGDM_EST_A_Fault	351	849
P0352	Cylinder 2 Ignition Coil Malfunction	KsDGDM_EST_B_Fault	352	850
P0505	Idle Speed Control Error	KsDGDM_IdleControl	505	1285
P0562	System Voltage Low	KsDGDM_SysVoltLow	562	1378

Fault Code of Electronic Injection System 11-3

P0563	System Voltage High	KsDGDM_SysVoltHigh	563	1379
P0650	MIL Circuit Malfunction	KsDGDM_MIL_Circuit	650	1616
P1693	Tachometer Circuit Low Voltage	KsDGDM_TAC_Circuit_Low	1693	5779
P1694	Tachometer Circuit High Voltage	KsDGDM_TAC_Circuit_High	1694	5780
P0137	O2S 2 Circuit Low Voltage	KsDGDM_O2_2_ShortLow	137	311
P0138	O2S 2 Circuit High Voltage	KsDGDM_O2_2_ShortHigh	138	312
P0038	O2S Heater 2 Circuit High Voltage	KsDGDM_O2_HeaterShortHigh	38	56
P0037	O2S Heater 2 Circuit Low Voltage	KsDGDM_O2_HeaterShortLow	37	55
P0500	VSS No Signal	KsDGDM_VSS_NoSignal	500	1280
P0850	Park Neutral Switch Error	KsDGDM_ParkNeutralSwitch	850	2128
P0445	CCP short to high	KsDGDM_CCP_CircuitShortHigh	445	1093
P0444	CCP short to low/open	KsDGDM_CCP_CircuitShortLow	444	1092
P0171	BLM Max Adapt(Kohler Special)	KsFDIAG_BLM_MaxAdapt	171	369
P0172	BLM Min Adapt(Kohler Special)	KsFDIAG_BLM_MinAdapt	172	370
P0174	PE System Lean(Kohler Special)	KsFDIAG_PESystLean	174	372

Hisun Motors Corp., U.S.A. Emission Control System Warranty Statement

YOUR WARRANTY RIGHTS AND OBLIGATIONS

The U.S. Environmental Protection Agency and **Hisun Motors Corp., U.S.A.** (hereinafter “**HISUN**”) are pleased to explain the emission control system warranty on your Off-Road vehicle. New off-road motor vehicles must be designed, built and equipped to meet U.S. EPA Federal and California anti-smog standards. HISUN must warrant the emission control system on your vehicle for 5,000 km, or at least 30 months, whichever comes first, provided that there has been no abuse, neglect or improper maintenance of your vehicle. This off-road vehicle was designed to meet the emission standards for 10,000 km, or five years, whichever comes first.

Your emission control system warranty covers components whose failure would increase an engine’s emissions of any regulated pollutant

Where a warrantable condition exists, HISUN will repair your vehicle at no cost to you, including diagnosis, parts and labor.

If an emission-related part on your vehicle is defective, the part will be repaired or

Hisun Motors Corp., U.S.A. Emission Control System Warranty Statement

replaced by HISUN. This is your EMISSION CONTROL SYSTEM WARRANTY.

NOTICE! Use of this vehicle in any type of competitive event completely and absolutely voids this and all other warranties offered by HISUN.

OWNER'S WARRANTY RESPONSIBILITIES

As the vehicle owner, you are responsible for the performance of the required maintenance listed in your owner's manual. HISUN recommends that you retain all receipts covering maintenance on your vehicle, but HISUN cannot deny warranty solely for the lack of receipts or for your failure to ensure the performance of all scheduled maintenance.

You are responsible for presenting your vehicle to the HISUN dealer as soon as a problem exists. The warranty repairs should be completed in a reasonable amount of time, not to exceed 30 days.

As the vehicle owner, you should be aware that HISUN may deny your warranty

Hisun Motors Corp., U.S.A. Emission Control System Warranty Statement

coverage if your vehicle or a part has failed due to abuse, neglect, improper maintenance or unapproved modifications.

If you use your vehicle in any type of competitive event, this warranty is immediately and completely void.

If you have any questions regarding your warranty rights and responsibilities, you should contact Hisun Motors Corp., U.S.A., 310 E, University Drive, McKinney, TX 75069 (Phone: 972-446-0760 or Toll Free: 877-838-6188), or the U.S. Environmental Protection Agency at 2000 Traverwood Drive, Ann Arbor, MI 48105.



Hisun Motors Corp., U.S.A. Limited Warranty on Emission Control System

YOUR WARRANTY RIGHTS AND OBLIGATIONS

Hisun Motors Corp., U.S.A. warrants that each new off-road vehicle:

- A. is designed, built and equipped so as to conform at the time of initial retail purchase with all applicable regulations of the United States Environmental Protection Agency, and
 - B. is free from defects in material and workmanship which cause such vehicle to fail to conform to applicable regulations of the United States Environmental Protection Agency for the periods specified above.
- I. Coverage.** Warranty defects shall be remedied during customary business hours at any authorized HISUN dealer located within the United States of America in compliance with the Clean Air Act and applicable regulations of the United States Environmental Protection Agency. Any part or parts replaced under this warranty shall become the property of HISUN.



Hisun Motors Corp., U.S.A. Limited Warranty on Emission Control System

II. Limitations This Emission Control System Warranty shall not cover any of the following:

- A.** Repair or replacement as a result of
 - (1) accident,
 - (2) misuse,
 - (3) repairs improperly performed or replacements improperly installed, unless performed by a HISUN authorized dealer,
 - (4) use of improper replacement parts or accessories not conforming to specifications set forth by HISUN, which adversely affect performance and/or
 - (5) Use in competitive racing or related events.

- B.** Inspections, replacement of parts and other services and adjustments required for required maintenance.



Hisun Motors Corp., U.S.A. Limited Warranty on Emission Control System

C. Any vehicle equipped with an odometer or hour meter on which the odometer mileage or hour meter reading has been changed so that actual mileage cannot be readily determined.

III. Limited Liability

A. The liability of HISUN under this Emission Control System Warranty is limited solely to the remedying of defects in material or workmanship by an authorized HISUN dealer at its place of business during customary business hours. This warranty does not cover inconvenience or loss of use of the vehicle or transportation of the vehicle to or from the HISUN dealer. HISUN shall not be liable for any other expenses, loss or damage, whether direct, incidental, consequential or exemplary arising in connection with the sale or use of or inability to use the vehicle for any purpose. Some states do not allow the exclusion or limitation of any incidental or consequential damages, so the above limitations may not apply to you.



Hisun Motors Corp., U.S.A. Limited Warranty on Emission Control System

B. No express emission control system warranty is given by HISUN except as specifically set forth herein. Any emission control system warranty implied by law, including any warranty of merchantability or fitness for a particular purpose, is limited to the express emission control system warranty terms stated in this warranty. The foregoing statements of warranty are exclusive and in lieu of all other remedies. Some states do not allow limitations on how long an implied warranty lasts, so the above limitations may not apply to you.

C. No dealer is authorized to modify this Limited Emission Control System Warranty issued by HISUN.

IV. LEGAL RIGHTS. This warranty gives you specific legal rights, and you may also have other rights which vary from state to state.

V. This warranty is in addition to the limited vehicle warranty.

VI. ADDITIONAL INFORMATION. Any replacement part that is equivalent in



Hisun Motors Corp., U.S.A. Limited Warranty on Emission Control System

performance and durability may be used in the performance of any maintenance or repairs by the owner. However, HISUN is not liable for these parts. The owner is responsible for the performance of all required maintenance. Such maintenance may be performed at a service establishment or by any individual. The warranty period begins when the vehicle is placed into service.

If you have any questions regarding your warranty rights and responsibilities, you should contact Hisun Motors Corp., U.S.A., or the U.S. Environmental Protection Agency at 2000 Traverwood Drive, Ann Arbor, MI 48105.

Hisun Motors Corp., U.S.A.

310 E. University Drive

McKinney, TX 75069

Phone: 972-446-0760

Fax: 972-446-0765

Toll-Free: 877-838-6188



AXIS OFF-ROAD

310 E. UNIVERSITY DR.
MCKINNEY, TX 75069



@AXISOFFROAD

FOR QUESTIONS REGARDING YOUR
PRODUCT, PLEASE CONTACT HISUN AT:
(972) 446-0760 OR WWW.AXIS-OFFROAD.COM

COPYRIGHT © AXIS OFF-ROAD. ALL INFORMATION CONTAINED WITHIN THIS PUBLICATION IS BASED UPON THE LATEST PRODUCT SPECIFICATIONS AND INFORMATION AT THE TIME OF PUBLICATION. BECAUSE OF THE CONSTANT ENHANCEMENT IN THE QUALITY AND DESIGN OF PRODUCTION COMPONENTS, MINOR DISCREPANCIES MAY VARY BETWEEN THE ACTUAL VEHICLE AND THE INFORMATION PRESENTED IN THIS PUBLICATION. NO LIABILITY CAN BE ACCEPTED FOR OMISSIONS OR INACCURACIES. ANY REPRINTING OR REPRODUCTION, WHETHER WHOLE OR IN PART OF THIS PUBLICATION IS STRICTLY PROHIBITED.